

Offshore OSNA® 10



Copper-Nickel Alloy for Seawater Piping Systems

KME Germany GmbH & Co. KG
Offshore OSNA® 10
[GB]



Content

KME - The Company	1
The Material	2
Offshore Product Range	3
Pipes	4
Butt Welding Fittings	
• Elbows	6
• Tee Pieces (<i>equal and reduced</i>)	7
• Caps	12
• Reducers	14
• Saddle Pieces	16
• Welding Outlets	19
Flanges	
• Composite Weld Neck Flanges	20
• Composite Blind Flanges	23
• Solid Weld Neck Flanges	24
• Solid Slip-On Flanges	26
• Composite Slip-On Flanges	27
Capillary Brazing, Socket Weld Fittings and Miscellaneous	
• Elbows 45° / 90°	28
• Tees (<i>equal and reducing</i>)	30
• Couplings (<i>equal and reducing</i>)	32
• (Half-) Couplings	34
• Welding Ends	35
• Connectors (<i>female and male</i>)	36
• Male Unions	38
• Unions	39
• Hexagon Head/Flush Bushings	40
• Sprinkler Bushing	41
• Outlets (<i>threaded and socket welding type</i>)	42
• End Caps / NPT End Caps	44
• Male Nipple (<i>one / both</i>)	45
• Female / Male Adapter	46
• Hexagon Plug / Round Plug	47
Appendix	48
Design Scope	50
KME Quality Management	53

KME - The Company

KME as one of the largest manufacturers of copper and copper alloy products offers best possible product and engineering solutions in the various fields of industrial applications. As a leading supplier in the most diverse industries, KME serves the worlds market with a broad spectrum of technologically leading copper and copper-alloy tubes, strips and sheets of outstanding production quality.

Marine Applications

KME's business unit Marine Applications is specialized in the production of copper-nickel alloys for piping systems in shipbuilding, offshore installations and other marine applications. Since decades, these alloys are successfully used in:

- Merchant and military shipbuilding
- Offshore oil and gas installations
- Coastal petroleum and petrochemical processing plants
- Seawater desalination plants
- Coastal electricity generation plants

Copper-nickel alloys are widely applied in:

- Seawater cooling systems
- Fire water systems
- Sanitary systems
- Deck steam pipes
- Deluge systems
- Hydraulic and pneumatic systems
- Seawater feed lines to desalination and processing units
- Splash zone sheathing



The Material



KME OSNA®10-Alloy

The chemical composition of the KME's OSNA®10-alloy is modified to ensure the compliance with all international specifications. Controlled content of alloying elements and minimised concentration of impurities ensure reliable service and fabrication properties of the alloy.

Main Advantages of OSNA®10-Alloy

Despite the rough conditions in marine service and the highly corrosive nature of seawater, the product range provides a well balanced combination of technical and economical benefits:

- Straight forward alloying system with good weldability
- Excellent ductility and toughness
- Good erosion/corrosion performance
- Resistant to uniform and localised corrosion
- No effect of ambient seawater temperatures
- No effect of seawater chlorination
- Resistant to biofouling
- Resistant to stress-corrosion cracking
- Low maintenance costs

Comparison of Standard Specifications for OSNA®-10 (CuNi 90/10)

	KME Alloy OSNA®-10 (CuNi 90/10)	EN 1652/ 12420/12449 ¹⁾ CW352H	DIN 86019 WL 2.1972	EEMUA 144-1987 UNS C 7060 x	MIL-T-16420K ASTM B 466 ^{2)/} 467 C 70620	JIS H 3300 C 7060 T
Ni %	10.0 – 11.0	9.0 – 11.0	9.0 – 11.0	10.0 – 11.0	9.0 – 11.0	9.0 – 11.0
Fe %	1.5 – 1.8	1.0 – 2.0	1.5 – 1.8	1.5 – 2.0*	1.0 – 1.8	1.0 – 1.8
Mn %	0.6 – 1.0	0.5 – 1.0	0.5 – 1.0	0.5 – 1.0	max. 1.0	0.2 – 1.0
C %	max. 0.02	max. 0.05	max. 0.05	max. 0.05	max. 0.05	-
Pb %	max. 0.01	max. 0.02	max. 0.01	max. 0.01	max. 0.02	max. 0.05
S %	max. 0.005	max. 0.05	max. 0.005	max. 0.02	max. 0.02	-
P %	max. 0.02	max. 0.02	max. 0.02	max. 0.02	max. 0.02	-
Zn %	max. 0.05	max. 0.50	max. 0.05	max. 0.20	max. 0.50	max. 0.50
Sn %		max. 0.03	-	-	-	-
other imp.	max. 0.20	max. 0.20	max. 0.20	max. 0.30	-	-
Cu %	rem.	rem.	rem.	rem.	min. 86.5	+Ni+Fe+Mn min. 99.5

¹⁾ formerly BS 2871 Part 2

²⁾ equal to C 70600 for subsequent welding

* The iron content has been specified to improve corrosion resistance

Offshore Product Range

The OSNA®10 offshore product range is based on:

- EEMUA -144: 1987 Tubes¹ Seamless and Welded
- EEMUA -145: 1987 Flanges Composite and Solid
- EEMUA -146: 1987 Fittings

The unique dimensional range from ½ inch to 36 inch ensures the supply of the entire piping systems from one source. Although the pipe dimensions of 38 and 40 inch are not included in the EEMUA 144 - 1987 they are available here as they are commonly specified in offshore projects. Based on ASME specifications, additional components are included.

Furthermore, we are also offering sheets and plates in different sizes.

¹ The reference „pipe“ rather than „tube“ is used in this document.



Seamless Pipes

Seamless pipes are in accordance with EEMUA-144, Section 1. They are manufactured from hot extruded shells followed by cold work and annealing.

Welded Pipes

Longitudinally welded pipes are in accordance with EEMUA-144, Section 2. They are manufactured from hot rolled or cold rolled and annealed sheet or plates in accordance with BS 2870, BS 2875, ASTM B171 or ASTM B402. Mechanical testing is carried out in accordance with the standards above. The pipes are supplied in “as welded” condition.

Dimensions

Dimensions are based on EEMUA -144, Tables 1.2.1-1.2.2 and 2.2.1-2.2.2. However, the pipe diameters range from ½ in./16 mm to 36 in./914 mm. Although the pipe diameters of 38 in./965 mm and 40 in./1016 mm are not included in the EEMUA 144 - 1987 they are available on request as they are commonly specified. The corresponding wall thicknesses of the pipes comply with the pressure containment requirements of ASME B31.3 as well as the requirements of the International Association of Classification Societies. Pipes with other wall thicknesses are available on request.

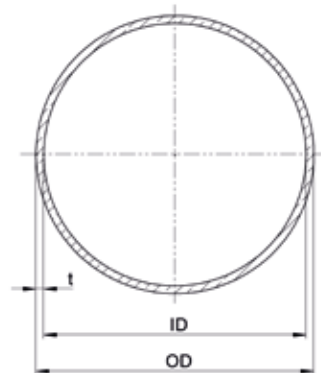

Tolerances

See notes 1-4 for seamless and notes 2-4 for welded pipes.

Weld Preparation

For wall thickness less than 3 mm, the pipes are supplied with plain weld ends. Larger thicknesses are supplied with the weld bevel of $37 \frac{1}{2} \pm 2 \frac{1}{2}^\circ$.



Dimensions (mm)**Seamless Pipe**

Size		Specified Wall Thickness (mm) t		Theoretical Weight/Metre (kg)	
Nominal (in)	Specified (mm)	16 bar	20 bar	16 bar	20 bar
½	16	2.0	2.0	0.78	0.78
¾	25	2.0	2.0	1.29	1.29
1	30	2.5	2.5	1.93	1.93
1¼	38	2.5	2.5	2.49	2.49
1½	44.5	2.5	2.5	2.94	2.94
2	57	2.5	2.5	3.82	3.82
2½	76.1	2.5	2.5	5.15	5.15
3	88.9	2.5	2.5	6.05	6.05
4	108	3.0	3.0	8.82	8.82
6	159	3.0	3.5	13.10	15.24
8	219.1	4.0	4.5	24.10	27.04
10	267	4.5	5.5	33.10	40.27
12	323.9	5.5	7.0	49.05	62.10
14	368	6.5	8.0	65.80	80.64
16	419	7.0	9.0	80.75	103.32

Seam-Welded Pipe

Size		Specified Wall Thickness (mm) t		Theoretical Weight/Metre (kg)	
Nominal (in)	Specified (mm)	16 bar	20 bar	16 bar	20 bar
16	419		9.0		103.32
18	457.2	8.0	9.5	100.62	119.10
20	508	8.5	11.0	118.90	153.10
24	610	10.5	13.0	176.30	217.30
28	711	12.0	15.0	234.90	292.21
32	813	13.5	17.0	302.20	378.76
36	914	15.5	19.0	390.00	475.97

Note 1

The pipe sizes up to including 4 in./108 mm are based on BS 2871: Part 2: Table 3 for outside diameters and their tolerances to allow for the use of capillary and compression fittings and brazed (and welded) slip-on flanges. The wall thickness of the 16 bar range have been increased to match the 20 bar range for mechanical strength.

Note 2

The pipe size 6 in./159 mm up to 16 in./419 mm are also based on BS 2871: Part 2: Table 3 for specified diameters but the tolerance have been applied to the inside diameters for facilitate alignment of matching weld preparations.

Note 3

The ovality of the finished pipe doesn't exceed 2% of the difference of the maximum and minimum diameter measured on the same cross section.

Note 4

Up to including 4 in./108 mm, the wall thickness doesn't vary by more than 10 % specified therein. For diameters from 6 in./159 mm and larger, the wall thickness is not less than 12.5 % of the specified value. The pipes with other dimensions than mentioned herein are available on request. Please contact us for more information.

Stock Dimensions

All seamless pipes are available from stock.

Type and Construction

Elbows are in accordance with EEMUA-146, Section 1. Seamless elbows are typically available up to 18 inch/457 mm. Larger dimensions are manufactured from longitudinally welded half shells. 45° and 90° elbows are available in all sizes.

Dimensions

Dimensions are based on EEMUA-146, Section 1, Figure 1.1, Tables 1.1-1.2 and 1.4-1.5., Standard elbows are supplied with long radius, i.e. 1.5 x O.D. Elbows with other dimensions are available on request.

Tolerances

See Appendix C

Weld Preparation

For wall thickness less than 3 mm, the elbows are supplied with plain weld ends. Larger thicknesses are supplied with the weld bevel of $37\frac{1}{2}^{\circ} \pm 2\frac{1}{2}^{\circ}$.

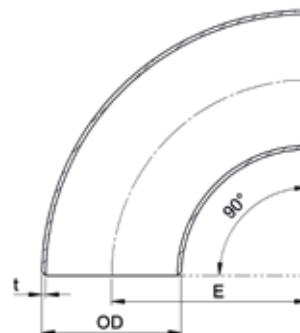

Dimensions (mm)

Nominal Size in	Specified Size (OD) mm	Specified Pipe Wall Thickness t		E		Approx. Weight (kg)					
		16 bar	20 bar	45°	90°	45° 16 bar	45° 20 bar	90° 16 bar	90° 20 bar		
1	30	Use 20 bar	2.5	22	38	Use 20 bar	0.06	Use 20 bar	0.12		
1¼	38		2.5	25	43		0.09		0.13		
1½	44.5		2.5	29	57		0.15		0.30		
2	57		2.5	35	76		0.25		0.52		
2½	76.1		2.5	44	95		0.45		0.90		
3	88.9		2.5	51	114		0.65		1.25		
4	108		3.0	64	152		1.00		2.10		
6	159		3.0	95	229		2.30		2.70	4.70	5.50
8	219.1		4.0	127	305		6.00		6.50	12	13
10	267		4.5	159	381		10		12	20	24
12	323.9	5.5	190	457	17	23	35	45			
14	368	6.5	222	533	27	34	55	67			
16	419	7.0	254	610	38	50	77	99			
18	457.2	8.0	286	686	54	64	109	128			
20	508	8.5	318	762	71	92	142	184			
24	610	10.5	381	914	126	156	252	312			
28	711	12.0	438	1067	197	245	394	490			
32	813	13.5	502	1219	289	362	579	725			
36	914	15.5	565	1372	420	513	841	1026			

Type and Construction

Tee pieces are in accordance with EEMUA-146, Section 1. Seamless tee pieces are typically available up to 8 in./219 mm; bigger dimensions are welded.

Dimensions

Dimensions are based on EEMUA -146, Section 1, Figures 1.1-1.2, Tables 1.1-1.2 and 1.6. Tee pieces with other dimensions are available on request.

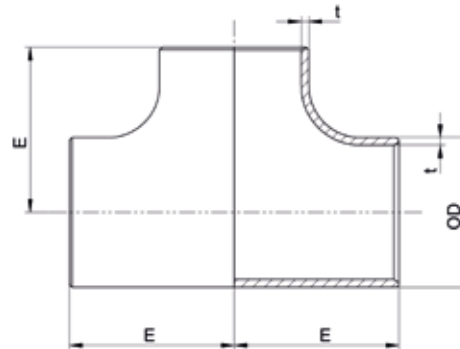

Tolerances

See Appendix C

Weld Preparation

For wall thickness less than 3 mm, the tees are supplied with plain weld ends. Larger thicknesses are supplied with the weld bevel of $37 \frac{1}{2} \pm 2 \frac{1}{2}^\circ$.



Dimensions (mm)

Nominal Size in	Specified Size (OD) mm	Specified Pipe Wall Thickness t mm		E	Approx. Weight (kg)	
		16 bar	20 bar		16 bar	20 bar
1	30	Use 20 bar	2.5	38	Use 20 bar	0.30
1¼	38		2.5	48		0.50
1½	44.5		2.5	57		0.75
2	57		2.5	64		1.00
2½	76.1		2.5	76		1.60
3	88.9		2.5	86		2.00
4	108		3.0	105		3.25
6	159	3.0	3.5	143	6.00	7.20
8	219.1	4.0	4.5	178	11.25	12.70
10	267	4.5	5.5	216	22.50	27.50
12	323.9	5.5	7.0	254	39.50	50.30
14	368	6.5	8.0	279	62.00	76.00
16	419	7.0	9.0	305	88.00	119.00
18	457.2	8.0	9.5	343	128.00	152.00
20	508	8.5	11.0	381	165.00	214.00
24	610	10.5	13.0	432	266.00	330.00
28	711	12.0	15.0	521	388.00	458.00
32	813	13.5	17.0	597	508.00	606.00
36	914	15.4	19.0	673	650.00	794.00

Reducing Tees (16 bar systems)

Type and Construction

Pieces are in accordance with EEMUA -146, Section 1. Seamless tee pieces are typically available up to 8 in./219 mm; bigger dimensions are welded.

Dimensions

Dimensions are based on EEMUA -146, Section 1, Figures 1.1-1.2, Tables 1.1-1.2 and 1.7.1-1.7.3. Tee pieces with other dimensions are available on request.

Tolerances

See Appendix C

Weld Preparation

For wall thickness less than 3 mm, the tees are supplied with plain weld ends. Larger thicknesses are supplied with the weld bevel of $37\frac{1}{2}^{\circ} \pm 2\frac{1}{2}^{\circ}$.

Dimensions for 16 bar systems

Specified Size			Pipe Wall Thickness			Centre-to-End (mm)		Approx. Weight kg
OD mm	OD mm	OD _i mm	t mm	t mm	t ₁ mm	E nom	E ₁ nom	
for sizes from 30 mm up to 108 mm use 20 bar								
		108			3.0		130	4.19
159	159	88.9	3.0	3.0	2.5	143	124	4.01
		76.1			2.5		121	3.96
		159			3.0		168	9.33
219.1	219.1	108	4.0	4.0	3.0	178	156	8.97
		88.9			2.5		152	8.82
		219.1			4.0		203	15.94
267	267	159	4.5	4.5	3.0	216	194	15.06
		108			3.0		184	14.71
		267			4.5		241	27.48
323.9	323.9	219.1	5.5	5.5	4.0	254	229	26.49
		159			3.0		219	25.62
		323.9			5.5		270	40.87
368	368	267	6.5	6.5	4.5	279	257	39.07
		219.1			4.0		248	38.20
		368			6.5		305	55.46
419	419	323.9	7.0	7.0	5.5	305	295	53.38
		267			4.5		283	51.62
		419			7.0		330	77.10
457.2	457.2	368	8.0	8.0	6.5	343	330	75.59
		323.9			5.5		321	73.45

Reducing Tees (16 bar systems)

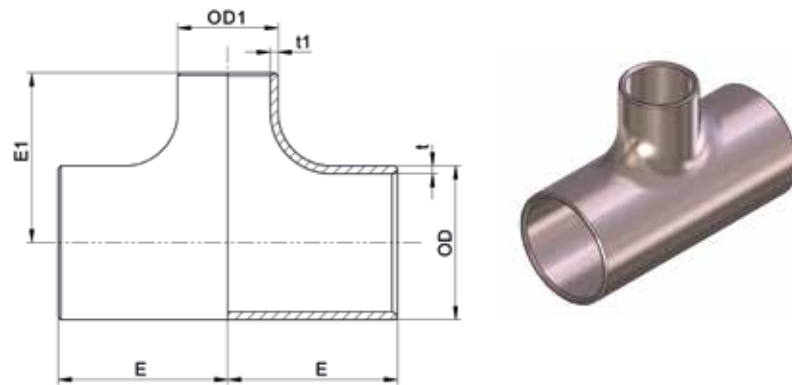

Dimensions for 16 bar systems

Specified Size			Pipe Wall Thickness			Centre-to-End (mm)		Approx. Weight kg
OD mm	OD mm	OD ₁ mm	t mm	t mm	t ₁ mm	E nom	E ₁ nom	
for sizes from 30 mm up to 108 mm use 20 bar								
		457.2			8.0		368	101.91
508	508	419	8.5	8.5	7.0	381	356	98.68
		368			6.5		356	97.16
		508			8.5		432	167.14
610	610	457.2	10.5	10.5	8.0	432	419	163.52
		419			7.0		406	160.21
		610			10.5		508	271.22
711	711	508	12.0	12.0	8.5	521	483	259.52
		457.2			8.0		470	255.88
		711			12.0		572	399.14
813	813	610	13.5	13.5	10.5	597	559	387.17
		508			8.5		533	375.34
		813			13.5		648	581.77
914	914	711	15.5	15.5	12.0	673	622	562.82
		610			10.5		610	551.05

Reducing Tees (20 bar systems)

Type and Construction

Pieces are in accordance with EEMUA -146, Section 1. Seamless tee pieces are typically available up to 8 in./219 mm; bigger dimensions are welded.

Dimensions

Dimensions are based on EEMUA -146, Section 1, Figures 1.1-1.2, Tables 1.1-1.2 and 1.7.1-1.7.3. Tee pieces with other dimensions are available on request.

Tolerances

See Appendix C

Weld Preparation

For wall thickness less than 3 mm, the tees are supplied with plain weld ends. Larger thicknesses are supplied with the weld bevel of $37 \frac{1}{2}^{\circ} \pm 2 \frac{1}{2}^{\circ}$.

Dimensions for 20 bar systems

Specified Size			Pipe Wall Thickness			Centre-to-End (mm)		Approx. Weight kg
OD mm	OD mm	OD ₁ mm	t mm	t mm	t ₁ mm	E nom	E ₁ nom	
30	30	25	2.5	2.5	2.0	38	38	0.18
38	38	30	2.5	2.5	2.5	48	48	0.29
		25	2.5	2.5	2.0			0.28
		38	2.5	2.5	2.5			0.42
44.5	44.5	30	2.5	2.5	2.5	57	57	0.40
		25	2.5	2.5	2.0			0.38
		44.5						60
57	57	38	2.5	2.5	2.5	64	57	0.56
		30					51	0.53
		57					70	0.90
76.1	76.1	44.5	2.5	2.5	2.5	76	67	0.87
		38					64	0.85
		76.1					83	1.24
88.9	88.9	57	2.5	2.5	2.5	86	76	1.16
		44.5					73	1.12
		88.9					98	2.12
108	108	76.1	3.0	3.0	2.5	105	95	2.06
		57					89	1.98
		108			3.0		130	4.80
159	159	88.9	3.5	3.5	2.5	143	124	4.62
		76.1			2.5		121	4.57
		159			3.5		168	10.50
219.1	219.1	108	4.5	4.5	3.0	178	156	10.02
		88.9			2.5		152	9.87
		219.1			4.5		203	19.25
267	267	159	5.5	5.5	3.5	216	194	18.29
		108			3.0		184	17.82

Reducing Tees (20 bar systems)

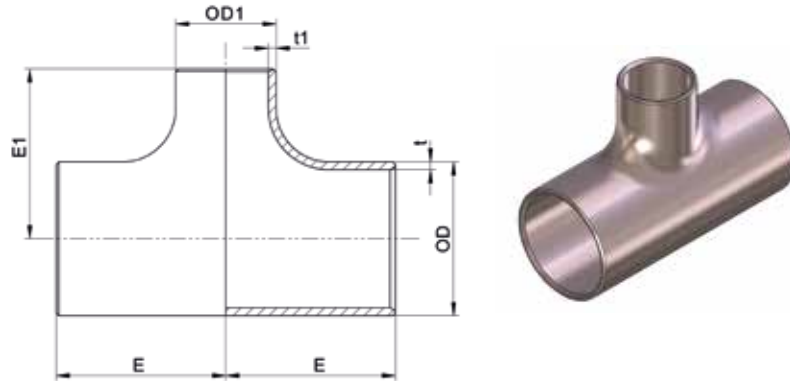

Dimensions for 20 bar systems

Specified Size			Pipe Wall Thickness			Centre-to-End (mm)		Approx. Weight kg
OD mm	OD mm	OD ₁ mm	t mm	t mm	t ₁ mm	E nom	E ₁ nom	
		267			5.5		241	34.69
323.9	323.9	219.1	7.0	7.0	4.5	254	229	33.32
		159			3.5		219	32.38
		323.9			7.0		270	50.27
368	368	267	8.0	8.0	5.5	279	257	47.87
		219.1			4.5		248	46.66
		368			8.0		305	70.63
419	419	323.9	9.0	9.0	7.0	305	295	68.24
		267			5.5		283	65.89
		419			9.0		330	92.04
457.2	457.2	368	9.5	9.5	8.0	343	330	89.74
		323.9			7.0		321	87.31
		457.2			9.5		368	130.03
508	508	419	11.0	11.0	9.0	381	356	127.00
		368			8.0		356	124.69
		508			11.0		432	206.90
610	610	457.2	13.0	13.0	9.5	432	419	201.04
		419			9.0		406	197.91
		610			13.0		508	337.26
711	711	508	15.0	15.0	11.0	521	483	323.65
		457.2			9.5		470	317.78
		711			15.0		572	500.07
813	813	610	17.0	17.0	13.0	597	559	484.85
		508			11.0		533	471.09
		813			17.0		648	712.24
914	914	711	19.0	19.0	15.0	673	622	688.14
		610			13.0		610	673.17

Type and Construction

End caps are in accordance with EEMUA -146, Section 1 and seamless.

Dimensions

Dimensions are based on EEMUA -146, Section 1, Figure 1.1, Tables 1.1-1.2 and 1.8. The additional wall compensatory thicknesses over and above the minimum pipe wall thicknesses are included. Caps with other dimensions are available on request.

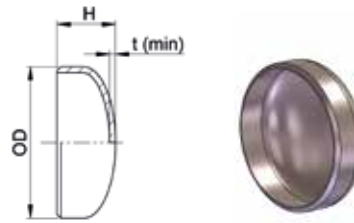

Tolerances

See Appendix C

Weld Preparation

For wall thickness less than 3 mm, the caps are supplied with plain weld ends. Larger thicknesses are supplied with the weld bevel of $37 \frac{1}{2} \pm 2 \frac{1}{2}^\circ$.

Specified Size OD	16 bar		20 bar		Approx. Weight	
	t min mm	H mm	t min mm	H mm	16 bar kg	20 bar kg
44.5	Use 20 bar		2.25	19.6	Use 20 bar	0.08
57			2.25	22.0		0.11
76.1			2.25	25.7		0.18
88.9			2.25	28.2		0.24
108			2.70	31.7		0.40
159	2.63	41	3.12	44	0.8	0.97
219.1	3.54	55	4.29	60	2.0	2.40
267	4.29	69	5.23	69	3.4	4.10
323.9	5.24	80	6.34	85	5.9	7.70
368	5.90	93	7.21	103	9.1	11.90
419	6.73	102	8.21	112	12.4	16.90
457.2	7.33	119	8.97	119	17.6	20.90
508	8.15	129	9.96	139	22.7	30.80
610	9.81	148	11.96	163	39.2	51.60
711	11.50	176	13.97	191	61.8	81.40
813	13.17	200	15.97	210	90.5	117.40
914	14.81	221	17.96	231	132.2	166.20

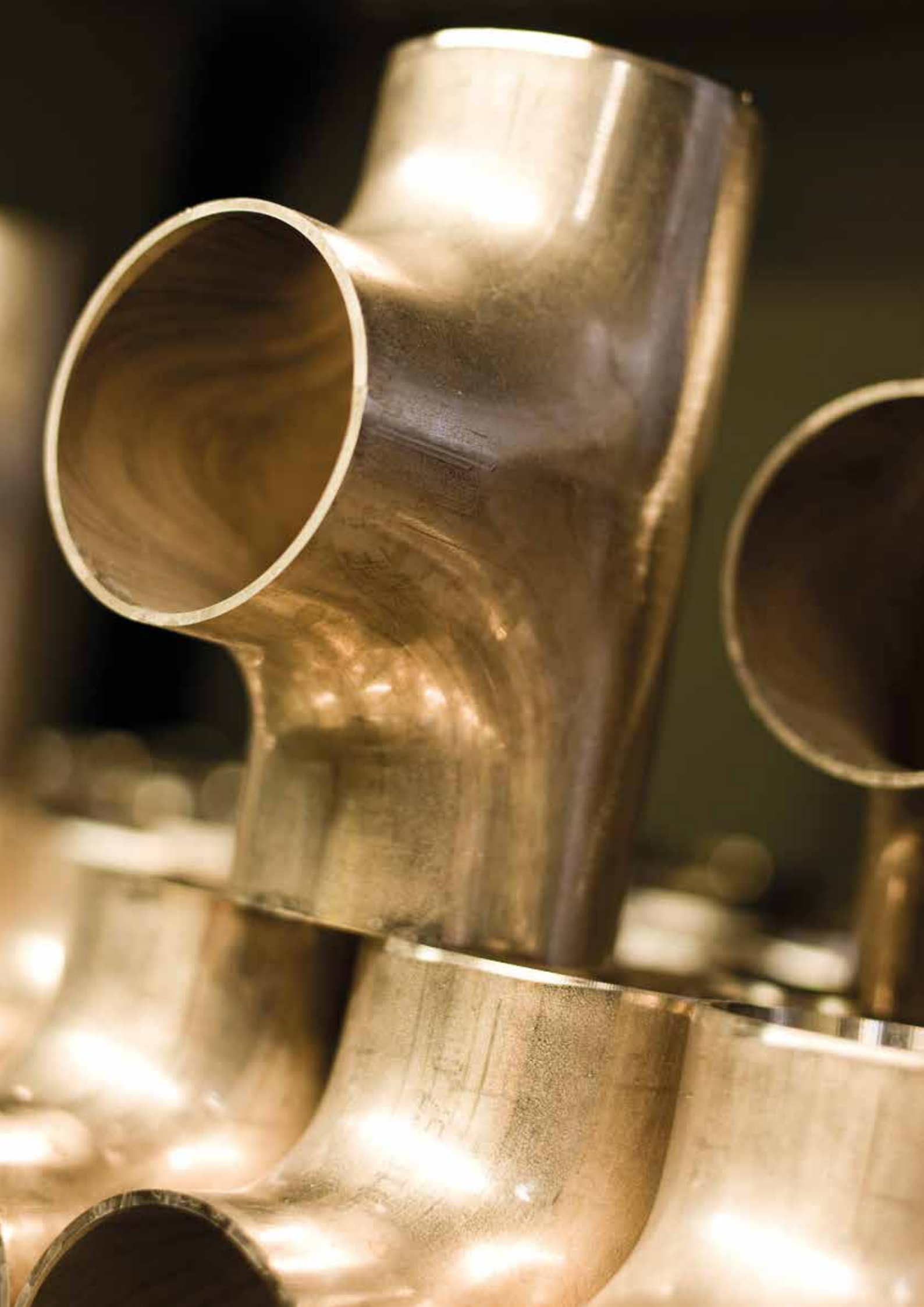

Type and Construction

Eccentric and concentric reducers are in accordance with EEMUA -146, Section 1. The concentric reducers are typically supplied up to incl. 12 in./323.9 mm in seamless condition; bigger dimensions are seamwelded. The eccentric reducers are supplied up to incl. 8 in./219.1 mm in seamless condition; bigger dimensions are seamwelded.

Dimensions

Dimensions are based on EEMUA -146, Section 1, Figures 1.1, Tables 1.1-1.2 and 1.9.1-1.9.3. Reducers with other dimensions are available on request.

Tolerances

See Appendix C

Weld Preparation

For wall thickness less than 3 mm, the reducers are supplied with plain weld ends. Larger thicknesses are supplied with the weld bevel of $37\frac{1}{2}^{\circ} \pm 2\frac{1}{2}^{\circ}$.

Specified Size OD x OD ₁ mm	Length H mm	Specified Wall Thickness t x t ₁		Approx. Weight	
		16 bar mm	20 bar mm	16 bar kg	20 bar kg
57 x 30	76	2.5 x 2.5	2.5 x 2.5	0.29	0.29
57 x 38	76	2.5 x 2.5	2.5 x 2.5	0.29	0.29
57 x 44.5	76	2.5 x 2.5	2.5 x 2.5	0.29	0.29
76.1 x 57	89	2.5 x 2.5	2.5 x 2.5	0.40	0.40
88.9 x 57	89	2.5 x 2.5	2.5 x 2.5	0.44	0.44
88.9 x 76.1	89	2.5 x 2.5	2.5 x 2.5	0.50	0.50
108 x 57	102	3.0 x 2.5	3.0 x 2.5	0.67	0.67
108 x 76.1	102	3.0 x 2.5	3.0 x 2.5	0.75	0.75
108 x 88.9	102	3.0 x 2.5	3.0 x 2.5	0.80	0.80
159 x 57	140	3.0 x 2.5	3.5 x 2.5	1.32	1.54
159 x 76.1	140	3.0 x 2.5	3.5 x 2.5	1.44	1.68
159 x 88.9	140	3.0 x 2.5	3.5 x 2.5	1.52	1.77
159 x 108	140	3.0 x 3.0	3.5 x 3.0	1.64	1.91
219.1 x 76.1	152	4.0 x 2.5	4.5 x 2.5	2.49	2.79
219.1 x 88.9	152	4.0 x 2.5	4.5 x 2.5	2.60	2.92
219.1 x 108	152	4.0 x 3.0	4.5 x 3.0	2.77	3.11
219.1 x 159	152	4.0 x 3.0	4.5 x 3.5	3.21	3.60
267 x 108	178	4.5 x 3.0	5.5 x 3.0	4.84	5.89
267 x 159	178	4.5 x 3.0	5.5 x 3.5	5.52	6.71
267 x 219.1	178	4.5 x 4.0	5.5 x 4.5	6.31	7.68
323.9 x 159	203	5.5 x 3.0	7.0 x 3.5	7.63	9.65
323.9 x 219.1	203	5.5 x 4.0	7.0 x 4.5	8.60	10.89
323.9 x 267	203	5.5 x 4.5	7.0 x 5.5	9.38	11.87

Reducers

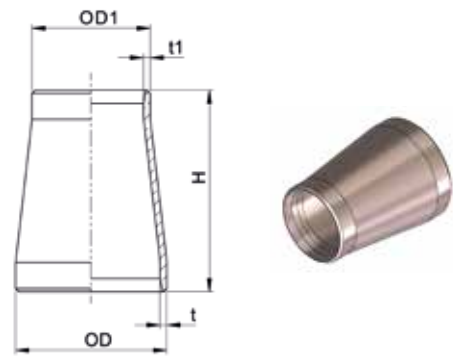
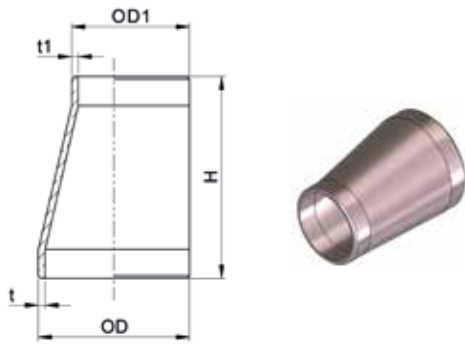

Specified Size OD x OD ₁ mm	Length H mm	Specified Wall Thickness t x t ₁		Approx. Weight	
		16 bar mm	20 bar mm	16 bar kg	20 bar kg
368 x 219.1	330	6.5 x 4.0	8.0 x 4.5	17.24	21.50
368 x 267	330	6.5 x 4.5	8.0 x 5.5	18.68	23.00
368 x 323.9	330	6.5 x 5.5	8.0 x 7.0	20.39	25.00
419 x 267	356	7.0 x 4.5	9.0 x 5.5	23.44	30.00
419 x 323.9	356	7.0 x 5.5	9.0 x 7.0	25.43	32.50
419 x 368	356	7.0 x 6.5	9.0 x 8.0	26.97	34.50
457.2 x 323.9	381	8.0 x 5.5	9.5 x 7.0	30.70	37.03
457.2 x 368	381	8.0 x 6.5	9.5 x 8.0	34.06	41.50
457.2 x 419	381	8.0 x 7.0	9.5 x 9.0	37.90	46.50
508 x 368	508	8.5 x 6.5	11.0 x 8.0	50.80	64.10
508 x 419	508	8.5 x 7.0	11.0 x 9.0	55.40	71.10
508 x 457.2	508	8.5 x 8.0	11.0 x 9.5	61.20	75.70
610 x 419	508	10.5 x 7.0	13.0 x 9.0	70.00	87.50
610 x 457.2	508	10.5 x 8.0	13.0 x 9.5	76.30	92.50
610 x 508	508	10.5 x 8.5	13.0 x 11.0	81.80	102.80
711 x 457.2	610	12.0 x 8.0	15 x 9.5	109.30	133.60
711 x 508	610	12.0 x 8.5	15 x 11.0	116.30	146.70
711 x 610	610	12.0 x 10.5	15 x 13.0	137.30	170.10
813 x 508	610	13.5 x 8.5	17 x 11	136.40	172.60
813 x 610	610	13.5 x 10.5	17 x 13	158.40	197.30
813 x 711	610	13.5 x 12.0	17 x 15	179.50	224.20
914 x 610	610	15.5 x 10.5	19 x 13	185.00	226.70
914 x 711	610	15.5 x 12	19 x 15	207.10	255.00
914 x 813	610	15.5 x 13.5	19 x 17	231.30	285.80

Type and Construction

Saddle pieces are in accordance with EEMUA -146, Section 7. Saddle pieces up to including 12 in./323.9 mm are supplied in seamless. Larger dimensions are manufactured from seamless or welded pipes as well as plates.

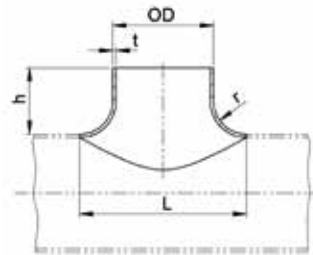

Seamless



Dimensions

Dimensions are based on EEMUA -146, Section 7, Figures 7.1-7.3 and Tables 7.1.1-7.3.2. Saddle pieces with other dimensions are available on request.

Tolerances

The tolerances are based on EEMUA - 146, Section 7, Tables 7.2.1-7.3.2.

Weld Preparation

Welding ends of butt weld ends for wall thickness less than 3 mm, the saddle pieces are supplied with plain weld ends. Larger thicknesses are supplied with the weld bevel of $37 \frac{1}{2}^{\circ} \pm 2 \frac{1}{2}^{\circ}$.

Seamless saddle pieces

Header Specified OD mm	Branch Size Range mm	t		Dimension	Tolerance on	Dimension	Tolerance on	r mm
		16 bar mm	20 bar mm	L mm	L mm	h mm	h mm	
All header sizes equal to or larger than branch up to and including	323	5.5	7.0	560	± 6	185	± 2.5	100
	267	4.5	5.5	447	± 5	155	± 2.5	90
	219.1	4.0	4.5	379	± 5	125	± 1.6	80
	159	3.0	3.5	279	± 4	95	± 1.6	60
	108	3.0	3.0	188	± 4	75	± 1.6	40
	88.9	2.5	2.5	149	± 3	55	± 1.6	30
	914 x 15.5 (16 bar)	76.1	2.5	2.5	126	± 3	50	± 1.6
610 x 13 (20 bar)	57	2.5	2.5	97	± 3	40	± 1.6	20
	44.5	2.5	2.5	74	± 3	35	± 1.6	15
	38	2.5	2.5	64	± 3	35	± 1.6	13

Note

Other sizes and reducing saddles are available on request.

Saddle Pieces (16 bar rating)

Type and Construction

Saddle pieces are in accordance with EEMUA -146, Section 7. Saddle pieces up to including 12 in./323.9 mm are supplied in seamless. Larger dimensions are manufactured from seamless or welded pipes as well as plates.

Dimensions

Dimensions are based on EEMUA -146, Section 7, Figures 7.1-7.3 and Tables 7.1.1-7.3.2. Saddle pieces with other dimensions are available on request.

Tolerances

The tolerances are based on EEMUA - 146, Section 7, Tables 7.2.1-7.3.2.

Weld Preparation

Welding ends of butt weld ends for wall thickness less than 3 mm, the saddle pieces are supplied with plain weld ends. Larger thicknesses are supplied with the weld bevel of $37\frac{1}{2}^{\circ} \pm 2\frac{1}{2}^{\circ}$.

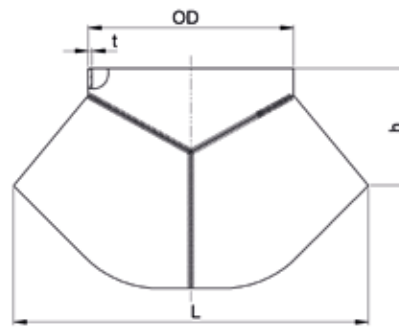

Seamwelded



Seamwelded saddle pieces - 16 bar rating

Header Specified OD mm	Branch Size Range mm	Dimension	Tolerance on	Dimension	Tolerance on
		L mm	L mm	h mm	h mm
All header sizes equal to or larger than branch in the range 323.9 x 5.5 up to and including 914 x 15.5	914 x 15.5	1550	± 7	460	± 3.5
	813 x 13.5	1400	± 7	410	± 3.5
	711 x 12	1225	± 7	360	± 3.5
	610 x 10.5	1020	± 7	300	± 3.0
	508 x 8.5	880	± 6	275	± 3.0
	457.2 x 8.0	800	± 6	250	± 3.0
	419 x 7.0	680	± 6	225	± 3.0
	368 x 6.5	613	± 6	200	± 3.0
	323.9 x 5.5	560	± 6	185	± 2.5
	267 x 4.5	447	± 5	155	± 2.5
219.1 x 4.0	379	± 5	125	± 1.6	

Saddle Pieces (20 bar rating)

Type and Construction

Saddle pieces are in accordance with EEMUA -146, Section 7. Saddle pieces up to including 12 in./323.9 mm are supplied in seamless. Larger dimensions are manufactured from seamless or welded pipes as well as plates.

Dimensions

Dimensions are based on EEMUA -146, Section 7, Figures 7.1-7.3 and Tables 7.1.1-7.3.2. Saddle pieces with other dimensions are available on request.

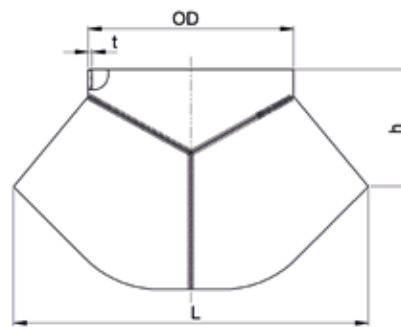

Seamwelded



Tolerances

The tolerances are based on EEMUA - 146, Section 7, Tables 7.2.1-7.3.2.

Weld Preparation

Welding ends of butt weld ends for wall thickness less than 3 mm, the saddle pieces are supplied with plain weld ends. Larger thicknesses are supplied with the weld bevel of $37 \frac{1}{2} \pm 2 \frac{1}{2}^\circ$.

Seamwelded saddle pieces - 20 bar rating

Header Specified OD mm	Branch Size Range mm	Dimension	Tolerance on	Dimension	Tolerance on
		L mm	L mm	h mm	h mm
All header sizes equal to or larger than branch in the range 323.9 x 7.0 up to and including 610 x 13	610 x 13	1020	± 7	300	± 3.0
	508 x 11	880	± 7	275	± 3.0
	457.2 x 9.5	800	± 6	250	± 3.0
	419 x 9.0	680	± 6	225	± 3.0
	368 x 8.0	613	± 6	200	± 3.0
	323.9 x 7.0	560	± 6	185	± 2.5
	267 x 5.5	447	± 5	155	± 2.5
	219.1 x 4.5	379	± 5	125	± 1.6

Welding Outlets

Self Reinforced Branch Connector - Butt Welding Type

Type and Construction

Welding outlets are in accordance with EEMUA-146, Section 6. The components are manufactured by hot forging and machining from extruded bars (solid or hollow).

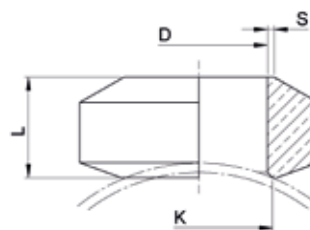

section view

Dimensions

The dimensions and tolerances are suitable for welding to seamless and seam-welded pipes to EEMUA - 144. The branch size covered is from ½ in./ 16 mm to 16 in./419 mm. Other branch sizes are available on request. The welding outlets covered are suitable for application to header sizes from ½ in./16 mm to 38 in./965 mm. The sizes of the header pipes for a given branch size are consolidated in accordance with MSS SP-97, Section 3.3 and Figure 1, whereas the gap distance between the header pipe radius and the fitting inlet radius doesn't exceed 1/16 in./1.6 mm.

The design of the self reinforced connection is in accordance with ASME B31.3 Section 304.3 suitable for both 16 and 20 bar pressure ratings. The additional design feature is the smooth entry into the connection to reduce the turbulences.

The overall dimensions are based on EEMUA -146, Section 6, Table 6.1.

Branch Specified OD mm	Header Size Range mm	L Nom mm	D mm	K Nom mm	S min/max mm
16	16 - 965	18	11.57 - 12.45	12.8 - 17.0	1.8 - 2.0
25	25 - 965	23	20.58 - 21.45	26.0 - 26.0	1.8 - 2.0
30	30 - 965	26	24.48 - 25.56	31.0 - 31.0	2.25 - 2.5
38	38 - 965	29	32.49 - 33.57	34.8 - 40.0	2.25 - 2.5
44.5	44.5 - 965	32	38.99 - 40.07	41.3 - 45.0	2.25 - 2.5
57	57 - 965	36	51.62 - 52.70	53.8 - 58.0	2.25 - 2.5
76.1	76.1 - 965	43	70.65 - 71.80	72.9 - 75.0	2.25 - 2.5
88.9	88.9 - 965	44 - 53	83.50 - 84.65	85.7 - 88.0	2.25 - 2.5
108	108 - 965	53	101.40 - 102.85	104.8 - 108.0	0.8 - 2.4
159	159 - 965	60	151.50 - 153.00	155.8 - 170.0	0.8 - 2.4
219.1	219.1 - 965	70	209.40 - 210.90	215.9 - 219.0	0.8 - 2.4
267	267 - 965	78	255.20 - 256.70	263.8 - 267.0	0.8 - 2.4
323.9	323.9 - 965	86	309.00 - 310.50	320.7 - 324.0	0.8 - 2.4
368	368 - 965	89	350.00 - 352.00	364.8 - 368.0	0.8 - 2.4
419	419 - 965	94	399.00 - 401.00	415.0 - 419.0	0.8 - 2.4

Composite Weld Neck Flanges

Weld Neck Stub Ends and Backing Flanges

Type and Construction

The weld neck stub ends are in accordance with EEMUA 145, Section 1A for 16 and 20 bar systems. The range of sizes covered is ½ in./16 mm to 36 in./914 mm. Other sizes are available on request. The stub ends are subdivided in two types short (Type S) based on DIN 86037 and long (Type L) based on MSS SP-43 suit the appropriate pipe dimension. The Type L stub ends are included to facilitate the attachments of this type of flange to butt weld welding fittings in accordance with EEMUA-146.

Dimensions

Dimensions are based on EEMUA-145, Section 1A, Tables 1.2-1.3.

Tolerances

The tolerances are based on EEMUA-145, Section 1A, Table 1.5.1.

Weld Preparation

The stub ends with $S1 < 3\text{mm}$ are supplied with plain weld ends. Larger dimension are supplied with the weld bevel of $37 \frac{1}{2}^{\circ} \pm 2 \frac{1}{2}^{\circ}$.

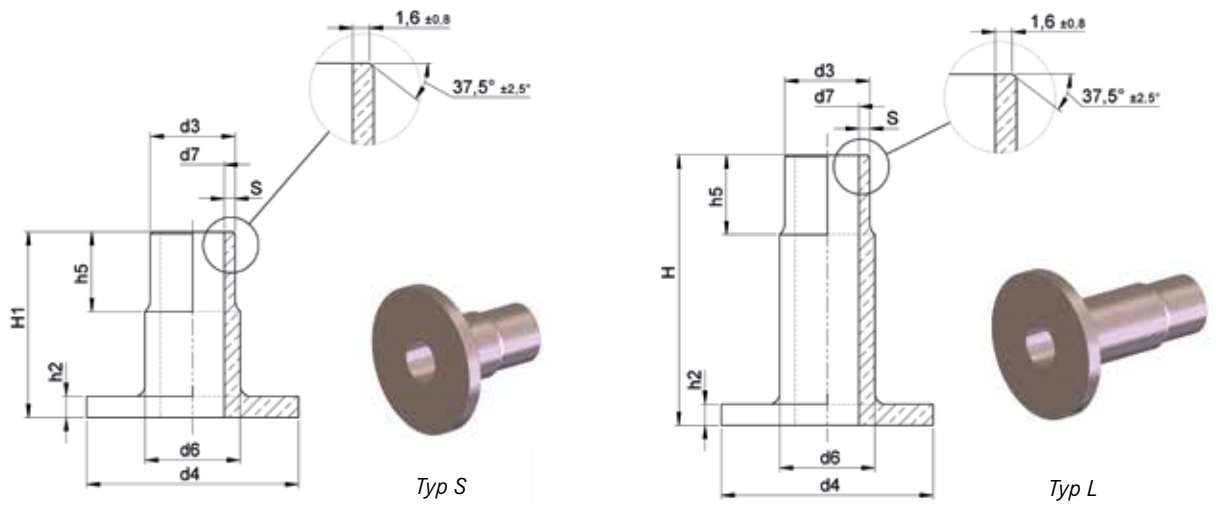

Nominal Size		16 bar					20 bar		Type S		Type L		16 bar S		20 bar S	
		d ₃	d ₄	d ₆	d ₇	d ₇	H ₁	H			h ₂	h ₅	min.	min.		
in	mm	mm	mm	mm	mm	mm	mm	mm	mm	mm	mm	mm	mm	mm	mm	
½	16	16	40	18	Use 20 bar	12.00	35	51	4	15	Use 20 bar	2.0				
¾	25	25	50	27		21.00	40	51	5	15		2.0				
1	30	30	60	32		25.00	40	51	5	15		2.5				
1¼	38	38	70	40		33.03	40	51	5	15		2.5				
1½	44.5	44.5	80	46.5		39.53	45	51	6	15		2.5				
2	57	57	99	59		52.16	45	64	6	15		2.5				
2½	76.1	76.1	120	78		71.23	45	64	6	15		2.5				
3	88.9	88.9	130	91		84.08	50	64	7	15		2.5				
4	108	108	158	110	102.13	50	76	7	15	3.0						
6	159	159	212	161.5	153.75	152.38	50	89	9	15	3.0	3.5				
8	219.1	219.1	270	222	211.10	210.10	50	102	9	15	4.0	4.5				
10	267	267	320	270	257.97	255.93	50	127	9	15	4.5	5.5				
12	323.9	323.9	370	327	312.83	309.74	50	152	11	16	5.5	7.0				
14	368	368	430	371	354.22	351.00	50	152	11	16	6.5	8.0				
16	419	419	482	422	404.17	399.84	50	152	12	16	7.0	9.0				
18	457.2	457.2	530	460	441.50	438.50	50	152	12	16	8.0	9.5				
20	508	508	585	511	490.50	486.50	50	152	12	20	8.5	11.0				
24	610	610	685	613	589.50	584.50	60	152	14	20	10.5	13.0				
28	711	711	800	719	687.50	681.50	60	190	19	24	12.0	15.0				
32	813	813	905	821	786.50	779.50	60	190	20.5	24	13.5	17.0				
36	914	914	1000	922	883.50	876.50	60	190	22	32	15.5	19.0				

Composite Weld Neck Flanges

Weld Neck Stub Ends and Backing Flanges

Type and Construction

The weld neck backing flanges are in accordance with EEMUA 145, Section 1B and are suitable for both 16 and 20 bar pressure rating. The range of sizes covered is ½ in./16 mm to 36 in./914 mm Class 150. Other sizes are available on request. Drilling and outside diameter dimensions of flange sizes ½ in./16 mm-24 in./610 mm are in accordance with ANSI/ASME B16.5 and BS 1560, whereas the larger sizes, 28 in./711 mm -36 in./914 mm are in accordance with MSS SP-44.

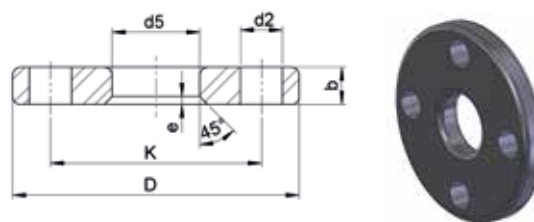

The backing flanges are manufactured from forged carbon steel in accordance with ASTM A105N. The chemical composition and mechanical properties of the components are in accordance with EEMUA 145, Section 1B, Table 1.6.2. The recommended bolting is in accordance with ASTM A193-B7. Unless otherwise specified the flanges are protected by hot dipped galvanising.

Dimensions

Dimensions are based on EEMUA -145, Section 1B, Table 1.4.

Tolerances

The tolerances are based on EEMUA - 145, Section 1B, Table 1.5.2.

Nominal Size		D mm	b min. mm	d ₂		d ₅ mm	K mm	No. of Bolts	e mm	Approx. Total Weight incl. Stub End – kg				
in	mm			in	mm					S	16 bar	L	S	20 bar
½	16	89	14	5/8	15.9	19	60.3	4	2	As for 20 bar	0.64	0.66		
¾	25	98	14	5/8	15.9	28	69.8	4	3		0.8	0.9		
1	30	108	14	5/8	15.9	33	79.4	4	3		1.0	1.0		
1¼	38	117	14	5/8	15.9	41	88.9	4	3		1.2	1.3		
1½	44.5	127	14	5/8	15.9	48	98.4	4	3		1.5	1.6		
2	57	152	18	¾	19.0	62	120.6	4	3		2.5	2.6		
2½	76.1	178	18	¾	19.0	81	139.7	4	3		3.3	3.4		
3	88.9	190	19	¾	19.0	94	152.4	4	3		3.8	3.9		
4	108	229	24	¾	19.0	113	190.5	8	3		6.6	6.9		
6	159	279	27	7/8	22.2	164	241.3	8	4		9.7	10.4	9.9	10.7
8	219.1	343	31	7/8	22.2	225	298.4	8	5	15.0	16.7	15.1	17.0	
10	267	406	38	1	25.4	273	362.0	12	5	23.1	26.6	23.5	27.5	
12	323.9	483	41	1	25.4	330	431.8	12	7	34.6	41.0	35.2	43.1	
14	368	533	45	1 1/8	28.6	374	476.2	12	7	44.7	53.4	45.5	55.8	
16	419	597	51	1 1/8	28.6	426	539.8	16	7	60.0	70.5	60.6	72.5	
18	457.2	635	52	1 ¼	31.8	465	577.8	16	7	66.0	78.0	68.0	84.3	
20	508	698	58	1 ¼	31.8	517	635.0	20	7	84.4	98.7	86.0	103.5	
24	610	813	71	1 3/8	34.9	618	749.3	20	9	131.4	149.8	134.0	156.5	
28	711	927	81	1 3/8	34.9	727	864.0	28	9	180.3	202.9	183.6	212.1	
32	813	1060	95	1 5/8	41.1	829	978.0	28	9	269.0	296.8	275.5	311.2	
36	914	1168	105	1 5/8	41.1	931	1086.0	32	9	335.8	369.8	341.0	385.8	

Type and Construction

The composite blind flanges are in accordance with manufacturer's specification. The range of sizes covered is ½ in./16 mm to 36 in./914 mm Class 150. Drilling and outside diameter dimensions of flange sizes ½ in./16 mm-24 in./610 mm are in accordance with ANSI/ASME Class 150, whereas the larger sizes, 28 in./711 mm -36 in./914 mm are in accordance with MSS SP-44. The blind flanges are suitable for use both 16 and 20 bar systems. The composite blind flanges are manufactured from forged carbon steel in accordance with ASTM A105N with a welded or bonded C70600 copper nickel disk. In contrast to raised face blind flanges in accordance to ANSI/ASME B16.5, the supplied composite flanges are considered as flat face, since the diameter of the copper nickel disk d1 is equivalent to the flange diameter d4 weld neck stub end in accordance with EEMUA 145, Section 1A. By these means, uniform contact over the weld neck stub end faces is ensured. The recommended bolting is in accordance with ASTM A193-B7 and ASTM A194-2H and should be suitably protected from corrosion. Unless otherwise specified the flanges are protected by hot dipped galvanising. Solid blind flanges are available on request.

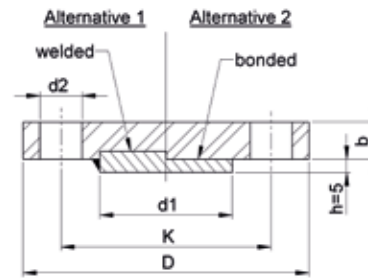

Tolerances

Tolerances are equivalent to the dimensions for weld neck backing flanges based on EEMUA -145, Section 1B, Table 1.5.2.

Nom. Size in	Spec. Size mm	Flange Diameter D mm	K mm	Diameter of Bolt Holes d ₂		Flange Thickness b min mm	Diameter of Disk d ₁ mm	No. of Bolt Holes	Approx. Total Weight (kg)
				in	mm				
½	16	89	60.3	5/8	15.9	14	40	4	0.82
¾	25	98	69.8	5/8	15.9	14	50	4	1.04
1	30	108	79.4	5/8	15.9	14	50	4	1.31
1¼	38	117	88.9	5/8	15.9	14	70	4	1.58
1½	44.5	127	98.4	5/8	15.9	14	80	4	1.90
2	57	152	120.6	¾	19.0	18	99	4	3.01
2½	76.1	178	139.7	¾	19.0	18	120	4	4.68
3	88.9	190	152.4	¾	19.0	19	130	4	5.70
4	108	229	190.5	¾	19.0	24	158	8	8.67
6	159	279	241.3	7/8	22.2	27	212	8	15.46
8	219.1	343	298.4	7/8	22.2	31	270	8	24.90
10	267	406	362.0	1	25.4	38	320	12	41.23
12	323.9	483	431.8	1	25.4	41	370	12	70.55
14	368	533	476.2	1 1/8	28.6	45	430	12	93.16
16	419	597	539.8	1 1/8	28.6	51	482	16	123.99
18	457.2	635	577.8	1 ¼	31.8	52	530	16	147.55
20	508	698	635.0	1 ¼	31.8	58	585	20	191.00
24	610	813	749.3	1 3/8	34.9	71	685	20	285.74
28	711	927	864.0	1 3/8	34.9	81	800	28	434.66
32	813	1060	978.0	1 5/8	41.1	95	905	28	665.63
36	914	1168	1086.0	1 5/8	41.1	105	1000	32	886.43

Type and Construction

The solid weld neck flanges are in accordance with EEMUA 145, Section 3 for 16 and 20 bar systems. The range of sizes covered is ½ in./16 mm to 36 in./914 mm Class 150. Other sizes are available on request. Drilling and outside diameter dimensions of flange sizes ½ in./16 mm-24 in./610 mm are in accordance with ANSI/ASME B16.5 and BS 1560, whereas the larger sizes, 28 in./711 mm -36 in./914 mm are in accordance with MSS SP-44. The recommended bolting is in accordance with ASTM B150 alloy UNS C63000.

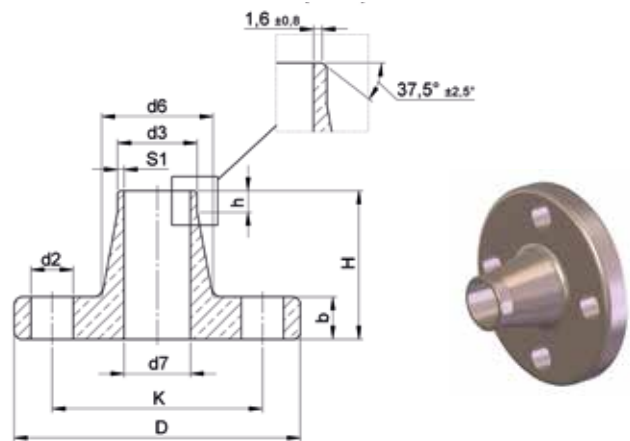

Dimensions

Dimensions are based on EEMUA -145, Section 3, Table 3.2-3.3.

Tolerances

The tolerances are based on EEMUA - 145, Section 3, Table 3.4.

Nominal Size	Outside Diameter of Flange		Thickn. of Flange	Diameter of Hub	Hub Dia at weld Chamfer	Length Through Hub	16 bar	20 bar
	D	b					Bore of Flange	Bore of Flange
in	mm	mm	mm	d ₆	d ₃	H	d ₇	d ₇
				mm	mm	mm	mm	mm
½	16	89	14	23	16	48	Use 20 bar	12.00
¾	25	98	16	32	25	52		21.00
1	30	108	16	42	30	56		25.00
1¼	38	117	17	51	38	57		33.03
1½	44.5	127	20	61	44.5	62		39.53
2	57	152	25	73	57	64		52.16
2½	76.1	178	27	91	76.1	70		71.23
3	88.9	190	27	105	88.9	70	84.08	
4	108	229	27	135	108	76	102.13	
6	159	279	27	192	159	89	153.75	152.38
8	219.1	343	31	246	219.1	98	211.10	210.10
10	267	406	31	305	267	98	257.97	255.93
12	323.9	483	35	365	323.9	98	312.83	309.74
14	368	533	41	400	368	99	354.22	351.00
16	419	597	43	457	419	106	404.17	399.84
18	457.2	635	45	505	457.2	113	441.50	438.50
20	508	698	45	559	508	118	490.50	486.50
24	610	813	49	664	610	137	589.50	584.50
28	711	927	72	748	711	145	687.50	681.40
32	813	1060	72	876	813	160	786.50	779.50
36	914	1168	72	984	914	175	883.50	876.50

It should be noted that although these flanges are flat faced, inside bolt circle gaskets shall be used and special care should be taken to avoid overtightening the bolting.



16 bar	20 bar	16 bar	20 bar	Parallel Length of Hub	Diameter of Bolt Circle	Drilling No. of Bolts	Diameter of Bolt Holes
Thickn. of Hub at Welding End S ₁ min mm	Thickn. of Hub at Welding End S ₁ min mm	Approx. Weight kg	Approx. Weight kg	h mm	K mm		d ₂ mm
Use 20 bar	2.0	Use 20 bar	0.72	8	60.3	4	15.9
	2.0		1.04	7	69.8	4	15.9
	2.5		1.3	8	79.4	4	15.9
	2.5		1.7	8	88.9	4	15.9
	2.5		2.3	7	98.4	4	15.9
	2.5		4.1	9	120.6	4	19.0
	2.5		6.1	8	139.7	4	19.0
	2.5		7.1	8	152.4	4	19.0
	3.0		10.2	8	190.5	8	19.0
	3.0		3.5	15.5	15.8	8	241.3
4.0	4.5	27.7	28.0	8	298.4	8	22.2
4.5	5.5	38.5	39.3	8	362.0	12	25.4
5.5	7.0	61.6	62.9	8	431.8	12	25.4
6.5	8.0	86.8	88.4	8	476.2	12	28.6
7.0	9.0	114.2	115.6	8	539.8	16	28.6
8.0	9.5	136.0	140.7	8	577.8	16	31.8
8.5	11.0	164.6	168.4	8	635.0	20	31.8
10.5	13.0	247.7	253.7	8	749.3	20	34.9
12.0	15.0	453.0	461.1	8	864.0	28	34.9
13.5	17.0	599.0	611.1	8	978.0	28	41.1
15.5	19.0	741.0	755.7	8	1086.0	32	41.1

Type and Construction

The solid slip-on flanges are in accordance with EEMUA 145, Section 4 and are suitable for both 16 and 20 bar systems. The range of sizes covered is ½ in./16 mm to 4 in./108 mm Class 150. Drilling and outside diameter dimensions are in accordance with ANSI/ASME B16.5 and BS 1560. The recommended bolting is in accordance with ASTM B150 alloy UNS C63000.

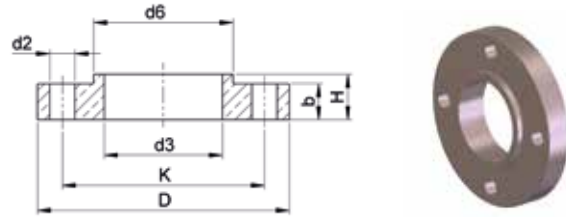

Dimensions

Dimensions are based on EEMUA -145, Section 4, Table 4.2.

Tolerances

The tolerances are based on EEMUA - 145, Section 4, Table 4.3.

Nominal Size		Flange Diameter	Flange Thickness	H	d ₆	No. of Bolt Holes	Diameter of Bolt Holes	K	Approx. Weight
in	mm	D	b	mm	mm		d ₂	mm	kg
½	16	89	14	20	23	4	15.9	60.3	0.66
¾	25	98	16	24	32	4	15.9	69.8	0.91
1	30	108	16	24	47	4	15.9	79.4	1.16
1¼	38	117	17	26	51	4	15.9	88.9	1.4
1½	44.5	127	20	26	61	4	15.9	98.4	1.9
2	57	152	25	28	73	4	19.0	120.6	3.3
2½	76.1	178	27	32	91	4	19.0	139.7	4.7
3	88.9	190	27	34	105	4	19.0	152.4	5.2
4	108	229	27	40	135	8	19.0	190.5	7.7

Composite Slip-On Flanges

Slip-On Stub Ends and Slip-On Backing Flanges

Type and Construction

The slip-on stub ends are in accordance with EEMUA 145, Section 2A and are suitable for 16 and 20 pressure rating. The range of sizes covered is ½ in./16 mm to 4 in./108 mm Class 150. The slip-on backing flanges are in accordance with EEMUA 145, Section 2B. Drilling and outside diameter dimensions are in accordance with ANSI/ASME B16.5 and BS 1560. The backing flanges are suitable for use in both 16 and 20 bar systems. The backing flanges are manufactured from forged carbon steel in accordance with ASTM A105N. The chemical composition and mechanical properties of the components are in accordance with EEMUA 145, Section 2B, Table 2.5.2. The recommended bolting is in accordance with ASTM A193-B7. Unless otherwise specified the flanges are protected by hot dipped galvanising.

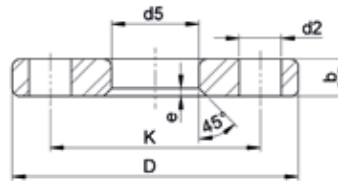
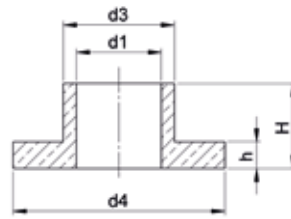

Dimensions

Dimensions are based on EEMUA -145, Section 2A and 2B, Tables 2.2 and 2.3.

Tolerances

The tolerances are based on EEMUA - 145, Section 2A and 2B, Tables 2.4.1 and 2.4.2.

Nominal Size		Inner Stub End Dimension					Outer Steel Flange – Dimension						No. of Bolt Holes	Approx. Total Weight (kg)
in	mm	d ₁ mm	d ₃ mm	d ₄ mm	H mm	h mm	D mm	b mm	K mm	d ₅ mm	d ₂ in/mm	e mm		
½	16	16.07	21	40	16	5	89	14	60.3	23	5/8 /15.9	3	4	0.61
¾	25	25.08	31	53	16	5	98	14	69.8	33	5/8 /15.9	3	4	0.75
1	30	30.08	36	60	18	5	108	14	79.4	38	5/8 /15.9	3	4	0.92
1¼	38	38.10	45	70	18	5	117	14	88.9	47	5/8 /15.9	3	4	1.10
1½	44.5	44.60	51	80	19	5	127	14	98.4	53	5/8 /15.9	3	4	1.30
2	57	57.23	67	99	19	6	152	18	120.6	69	¾ /19	3	4	2.20
2½	76.1	76.33	87	120	19	6	178	18	139.7	89	¾ /19	3	4	3.00
3	88.9	89.18	100	130	21	7	190	19	152.4	103	¾ /19	3	4	3.50
4	108	108.38	120	158	23	7	229	24	190.5	123	¾ /19	3	4	6.00

Capillary Brazing Elbow 45° Socket Welding Elbow 45°

CB

SW

Elbows 45°
16 mm – 57 mm

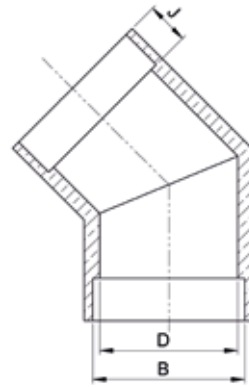
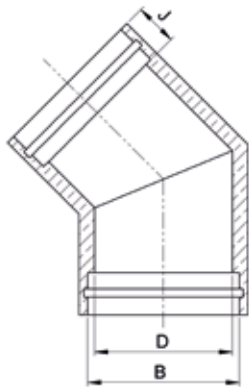

Dimensions Table 45°

nominal		specified	J		B		D	weight
in	mm		min	min/max	min/max	min		
			mm	mm	mm	mm	~kg	
½	16		10	16.070	16.121	12	0.080	
¾	25		13	25.080	25.131	21	0.139	
1	30		13	30.080	30.131	25	0.201	
1¼	38		13	38.095	38.146	33	0.289	
1½	44.5		13	44.595	44.646	39.5	0.402	
2	57		16	57.225	57.276	52	0.552	

Capillary Brazing Elbow 90° Socket Welding Elbow 90°

CB

SW

Elbows 90°
16 mm – 57 mm

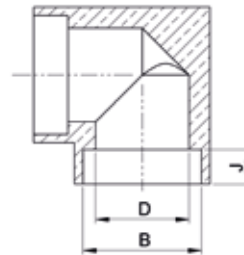
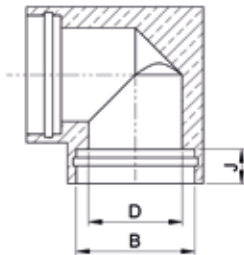

Dimensions Table 90°

nominal		specified	J		D		B		weight
in	mm		min	min	min/max		min/max		~kg
			mm	mm	mm		mm		
½	16		10	12	16.070	16.121			0.091
¾	25		13	21	25.080	25.131			0.170
1	30		13	25	30.080	30.131			0.248
1¼	38		13	33	38.095	38.146			0.406
1½	44.5		13	39.5	44.595	44.646			0.547
2	57		16	52	57.225	57.276			0.831

Capillary Brazing Equal Tees

Socket Welding Equal Tees

Equal Tees
16 mm – 57 mm

CB

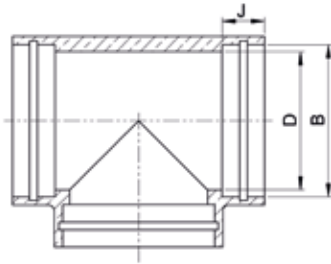

SW

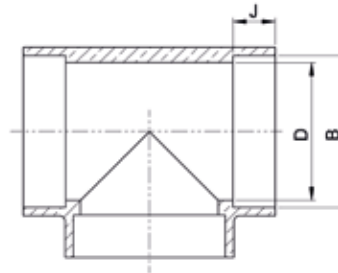

Dimensions Table Equal Tees

nominal in	specified mm	D		B		J	weight
		min mm	max/min mm	min mm	min mm	~kg	
½	16	12	16.121	16.070	10	0.107	
¾	25	21	25.131	25.080	13	0.193	
1	30	25	30.131	30.080	13	0.261	
1¼	38	33	38.146	38.095	13	0.428	
1½	44.5	39.5	44.646	44.595	13	0.567	
2	57	52	57.276	57.225	16	0.804	

Capillary Brazing Reducing Tees

Socket Welding Reducing Tees

CB

SW

Reducing Tees
16 mm – 57 mm

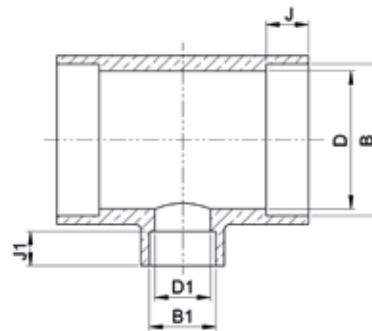
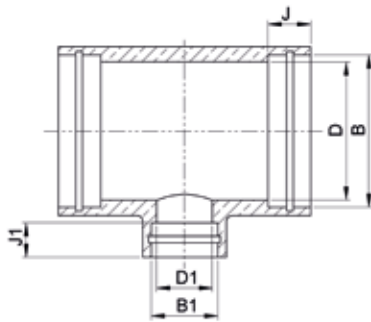

Dimensions Table Reducing Tees

nominal in	specified mm	D		B		J	D ₁	B ₁		J ₁	weight ~kg
		min mm	max/min mm	min mm	max/min mm	min mm	min mm	max/min mm	min mm		
3/4 x 1/2	25 x 16	21	25.131 25.080	13	12	16.121	16.070	10	0.196		
1 x 1/2	30 x 16	25	30.131 30.080	13	12	16.121	16.070	10	0.270		
1 x 3/4	30 x 25	25	30.131 30.080	13	21	25.131	25.080	13	0.269		
1 1/4 x 1/2	38 x 16	33	38.146 38.095	13	12	16.121	16.070	10	0.481		
1 1/4 x 3/4	38 x 25	33	38.146 38.095	13	21	25.131	25.080	13	0.454		
1 1/4 x 1	38 x 30	33	38.146 38.095	13	25	30.131	30.080	13	0.451		
1 1/2 x 1/2	44.5 x 16	39.5	44.646 44.595	13	12	16.121	16.070	10	0.651		
1 1/2 x 3/4	44.5 x 25	39.5	44.646 44.595	13	21	25.131	25.080	13	0.629		
1 1/2 x 1	44.5 x 30	39.5	44.646 44.595	13	25	30.131	30.080	13	0.623		
1 1/2 x 1 1/4	44.5 x 38	39.5	44.646 44.595	13	33	38.146	38.095	13	0.600		
2 x 1/2	57 x 16	52	57.276 57.225	16	12	16.121	16.070	10	0.972		
2 x 3/4	57 x 25	52	57.276 57.225	16	21	25.131	25.080	13	0.966		
2 x 1	57 x 30	52	57.276 57.225	16	25	30.131	30.080	13	0.961		
2 x 1 1/4	57 x 38	52	57.276 57.225	16	33	38.146	38.095	13	0.939		
2 x 1 1/2	57 x 44.5	52	57.276 57.225	16	39.5	44.646	44.595	13	0.911		

Capillary Brazing Equal Couplings Socket Welding Equal Couplings

**Equal
Couplings**
16mm - 57 mm

CB

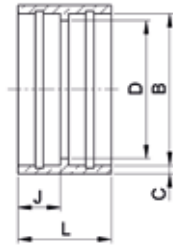

SW

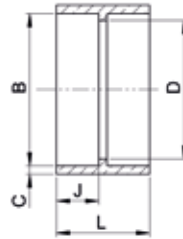

Dimensions Table Equal Couplings

nominal	specified	D		B	C	J	L	weight
		min	max/min	min	min	min		
in	mm	mm	mm	mm	mm	mm	mm	~kg
½	16	12	16.121 16.070	3.2	10	22	0.039	
¾	25	21	25.131 25.080	3.2	13	28	0.073	
1	30	25	30.131 30.080	3.2	13	28	0.087	
1¼	38	33	38.146 38.095	3.2	13	28	0.108	
1½	44.5	39.5	44.646 44.595	3.2	13	29	0.132	
2	57	52	57.276 57.225	3.2	16	35	0.201	

Capillary Brazing Reducing Couplings Socket Welding Reducing Couplings

Capillary Brazing, Socket Weld
Fittings and Miscellaneous

Reducing
Couplings
16 mm – 57 mm

CB

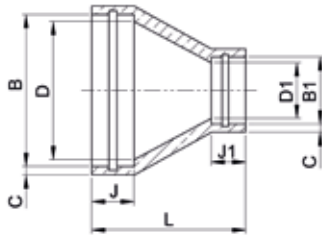

SW

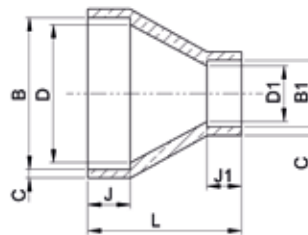

Dimensions Table Reducing Couplings

nominal in	specified mm	D		B	J	C	D ₁	B ₁		J ₁	L	weight ~kg
		min mm	max/min mm					max/min mm	min mm			
3/4 x 1/2	25 x 16	21	25.131	25.080	13	3.2	12	16.121	16.070	10	36	0.092
1 x 1/2	30 x 16	25	30.131	30.080	13	3.2	12	16.121	16.070	10	37	0.108
1 x 3/4	30 x 25	25	30.131	30.080	13	3.2	21	25.131	25.080	13	33	0.102
1 1/4 x 1/2	38 x 16	33	38.146	38.095	13	3.2	12	16.121	16.070	10	43	0.152
1 1/4 x 3/4	38 x 25	33	38.146	38.095	13	3.2	21	25.131	25.080	13	37	0.136
1 1/4 x 1	38 x 30	33	38.146	38.095	13	3.2	25	30.131	30.080	13	33	0.126
1 1/2 x 1/2	44.5 x 16	39.5	44.646	44.595	13	3.2	12	16.121	16.070	10	49	0.199
1 1/2 x 3/4	44.5 x 25	39.5	44.646	44.595	13	3.2	21	25.131	25.080	13	43	0.182
1 1/2 x 1	44.5 x 30	39.5	44.646	44.595	13	3.2	25	30.131	30.080	13	39	0.174
1 1/2 x 1 1/4	44.5 x 38	39.5	44.646	44.595	13	3.2	33	38.146	38.095	13	32	0.144
2 x 1/2	57 x 16	52	57.276	57.225	16	3.2	12	16.121	16.070	10	63	0.322
2 x 3/4	57 x 25	52	57.276	57.225	16	3.2	21	25.131	25.080	13	58	0.310
2 x 1	57 x 30	52	57.276	57.225	16	3.2	25	30.131	30.080	13	53	0.298
2 x 1 1/4	57 x 38	52	57.276	57.225	16	3.2	33	38.146	38.095	13	46	0.268
2 x 1 1/2	57 x 44.5	52	57.276	57.225	16	3.2	39.5	44.646	44.595	13	40	0.234

Capillary Brazing (Half)-Couplings Socket Welding (Half)-Couplings

(Half)-Couplings
16 mm – 57 mm

CB

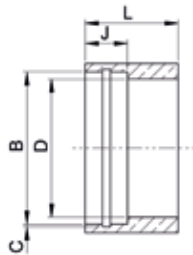

SW

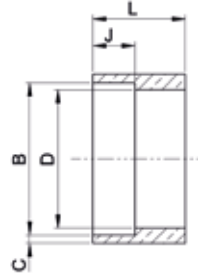

section view

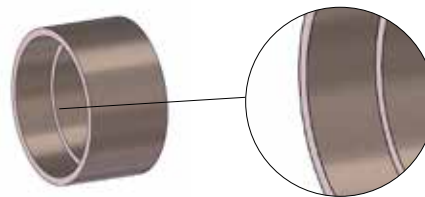
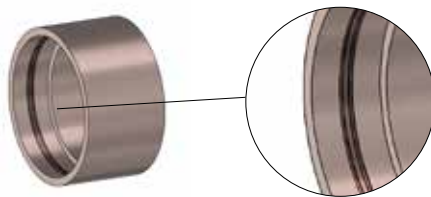

Dimensions Table Brazing (Half)-Couplings / Socket Welding (Half)-Couplings

nominal in	specified mm	D		B	C	J	L	Halfcoupling weight ~kg	Coupling weight ~kg
		min mm	max/min mm	max/min mm	min mm	min mm	min mm		
1/2	16	12	16.121	16.070	3.2	10	22	0.047	0.039
3/4	25	21	25.131	25.080	3.2	13	28	0.090	0.073
1	30	25	30.131	30.080	3.2	13	28	0.112	0.087
1 1/4	38	33	38.146	38.095	3.2	13	28	0.141	0.108
1 1/2	44.5	39.5	44.646	44.595	3.2	13	29	0.171	0.132
2	57	52	57.276	57.225	3.2	16	35	0.266	0.201

Welding Ends

Welding Ends
1/2" - 2"

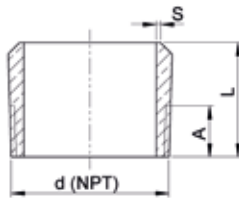

section view

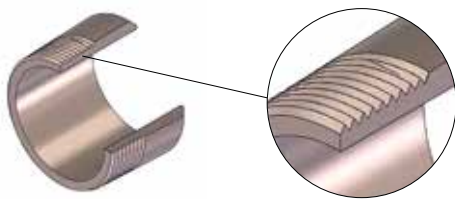

Dimensions Table Welding Ends

nominal		specified	d	L ₂	A	S	Coupling weight
in	mm		Thread NPT	mm	min mm	mm	~kg
1/2	21.3		1/2	24.0	13.6	1.6	0.049
3/4	26.7		3/4	25.5	13.9	1.6	0.076
1	33.4		1	30.0	17.3	1.6	0.131
1 1/4	42.2		1 1/4	33.5	18.0	1.6	0.196
1 1/2	48.3		1 1/2	39.5	18.4	1.6	0.298
2	60.3		2	43.0	19.2	1.6	0.488

Straight Female Connector

Connector 30
16 mm – 57 mm

CB

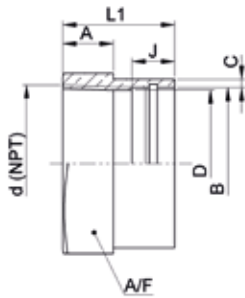

SW

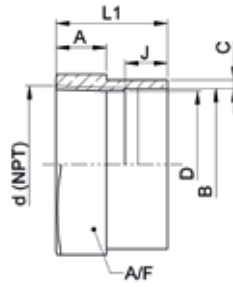

section view

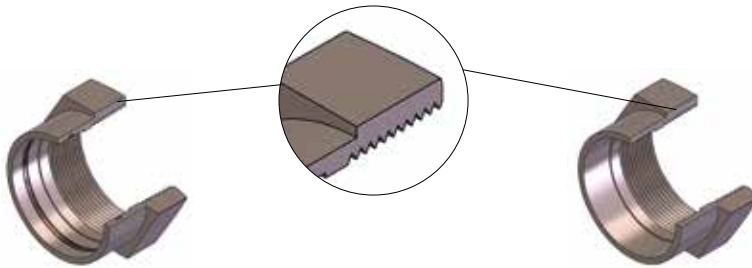

Dimensions Table Female

nominal		specified	d	B		C	L ₁	J	A	A/F	weight
in	mm		Thread NPT	max/min mm	mm	min mm	mm	min mm	min mm	mm	~kg
½	16		½	16.121 16.070		3.2	32	10	13.5	27	0.070
¾	25		¾	25.131 25.080		3.2	33	13	14	32	0.110
1	30		1	30.131 30.080		3.2	37	13	17.5	41	0.180
1¼	38		1¼	38.146 38.095		3.2	38	13	18	50	0.240
1½	44.5		1½	44.646 44.595		3.2	38	13	18.5	55	0.280
2	57		2	57.276 57.225		3.2	42	16	19	70	0.470

Straight Male Connector

Connector 30
16 mm – 57 mm

CB

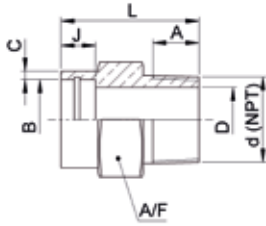

SW

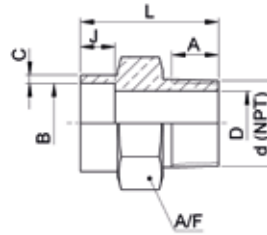

section view

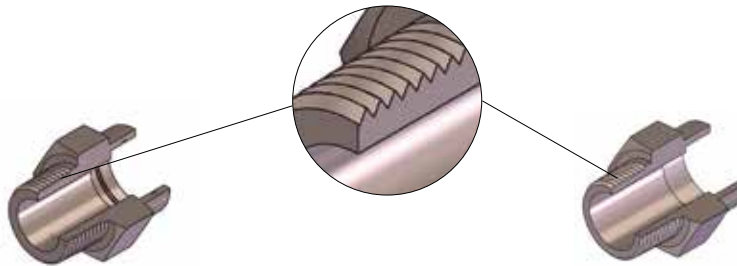

Dimensions Table Male

nominal in	specified mm	A Thread NPT	B		C min mm	D mm	L mm	J mm	A mm	A/F mm	weight ~kg
			max/min	mm							
1/2	16	1/2	16.121	16.070	3.2	13.8	40	10	13.5	27	0.090
3/4	25	3/4	25.131	25.080	3.2	18.9	46	13	14	32	0.150
1	30	1	30.131	30.080	3.2	24.3	52	13	17.5	41	0.250
1 1/4	38	1 1/4	38.146	38.095	3.2	32.5	54	13	18	50	0.350
1 1/2	44.5	1 1/2	44.646	44.595	3.2	38.1	57	13	18.5	55	0.440
2	57	2	57.276	57.225	3.2	49.2	63	16	19	70	0.720

Male Unions

Socket Welding Unions, Capillary Brazing Unions, Male Unions, Socket Welding x Male Thread,
Capillary Brazing x Male Thread

Male Unions
16 mm – 57 mm
male thread
3/4" – 2"

CB

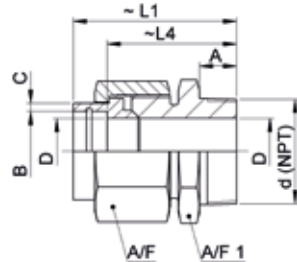

SW

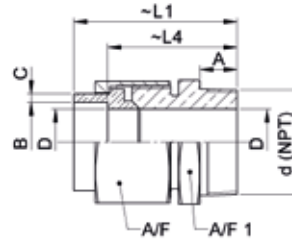

section view

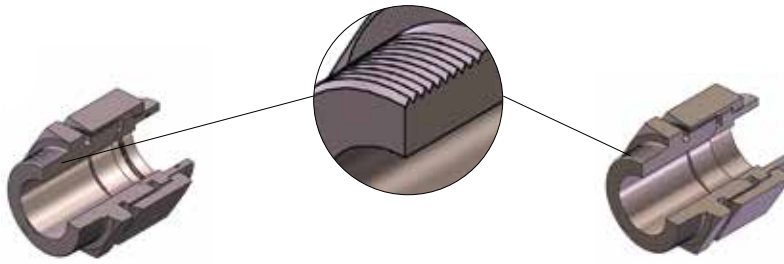

Dimensions Table Male Unions

nominal		specified	d	C	B		D	~L ₁	~L ₄	A	A/F	A/F ₁	weight
in	mm		Thread NPT	min mm	max/min mm		min mm	mm	mm	min mm	mm	mm	~kg
1/2	16	16 x 3/4	3/4	3.2	16.121	16.070	12.0	66	56	14	36	32	0.39
3/4	25	25 x 1	1	3.2	25.131	25.080	21.0	81	68	17.5	46	41	0.69
1	30	30 x 1 1/4	1 1/4	3.2	30.131	30.080	25.0	83.5	70.5	18	50	46	0.87
1 1/4	38	38 x 1 1/2	1 1/2	3.2	38.146	38.095	33.0	86.5	73.5	18.5	60	55	1.17
1 1/2	44.5	44.5 x 1 1/2	1 1/2	3.2	44.646	44.595	39.5	91.5	78.5	18.5	70	60	1.46
2	57	57 x 2	2	3.2	57.276	57.225	52.0	100.5	84.5	19	85	75	2.18

Unions

Unions
16 mm – 57 mm

CB

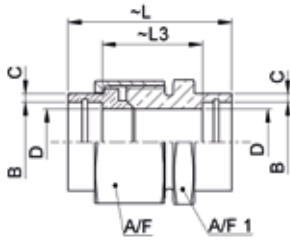

SW

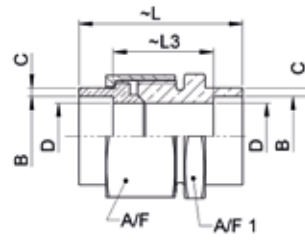

section view

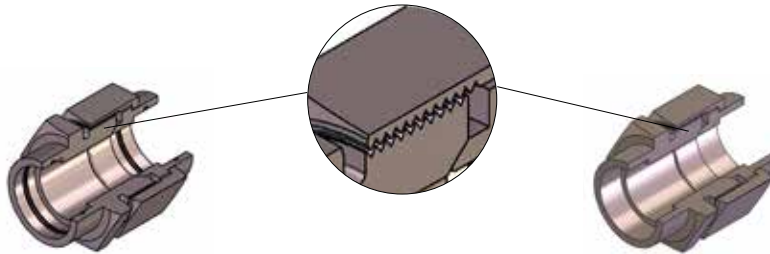

Dimensions Table Unions

nominal		specified	C		B		D	~L	~L ₃	A/F	A/F ₁	weight
in	mm		min	max/min	max/min	min	min	mm	mm	mm	mm	~kg
1/2	16		3.2	16.121	16.070	12.0	58	38	36	32	0.34	
3/4	25		3.2	25.131	25.080	21.0	71	45	46	41	0.62	
1	30		3.2	30.131	30.080	25.0	72.5	46.5	50	46	0.71	
1 1/4	38		3.2	38.146	38.095	33.0	75.5	49.5	60	55	1.02	
1 1/2	44.5		3.2	44.646	44.595	39.5	80.5	54.5	70	60	1.39	
2	57		3.2	57.276	57.225	52.0	91.5	59.5	85	75	2.12	

Hexagon Head and Flush Bushings

Hex. Head and Flush Bushings

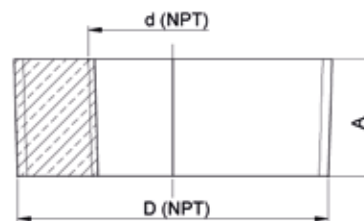
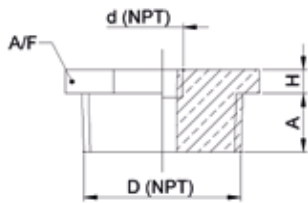

section view

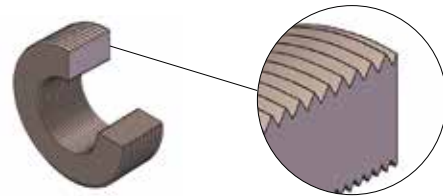
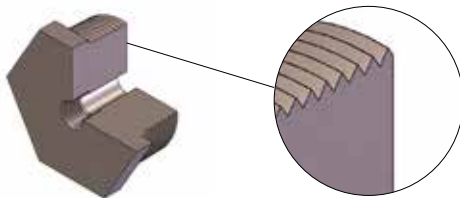

Dimensions Table

nominal size	Thread D	Thread d	A min	H	A/F	Hex. Head weight	Flush weight
in	NPT	NPT	mm	mm	mm	~kg	~kg
1/2	1/2	1/4	14.5	5	22	0.048	0.033
3/4	3/4	1/4	16.0	6	27	0.094	0.065
3/4	3/4	3/8	16.0	6	27	0.082	0.056
1	1	1/4	19.0	6	35	0.181	0.129
1	1	3/8	19.0	6	35	0.167	0.118
1	1	1/2	19.0	6	35	0.150	0.105
1 1/4	1 1/4	1/4	20.5	7	44.5	0.333	0.233
1 1/4	1 1/4	3/8	20.5	7	44.5	0.318	0.221
1 1/4	1 1/4	1/2	20.5	7	44.5	0.299	0.207
1 1/4	1 1/4	3/4	20.5	7	44.5	0.260	0.177
1 1/2	1 1/2	1/4	20.5	8	51	0.463	0.311
1 1/2	1 1/2	3/8	20.5	8	51	0.447	0.299
1 1/2	1 1/2	1/2	20.5	8	51	0.428	0.285
1 1/2	1 1/2	3/4	20.5	8	51	0.387	0.255
1 1/2	1 1/2	1	20.5	8	51	0.331	0.214
2	2	1/4	22.0	9	63.5	0.799	0.530
2	2	3/8	22.0	9	63.5	0.782	0.518
2	2	1/2	22.0	9	63.5	0.761	0.503
2	2	3/4	22.0	9	63.5	0.716	0.471
2	2	1	22.0	9	63.5	0.655	0.427
2	2	1 1/4	22.0	9	63.5	0.534	0.341
2	2	1 1/2	22.0	9	63.5	0.432	0.268

Sprinkler Bushing

Sprinkler Bushing
25 mm – 57 mm x
1" – 1 1/2" NPT

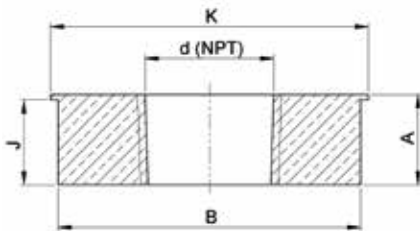

section view

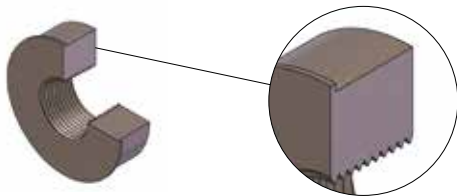

Dimensions Table

nominal in	specified mm	B		A	J	K	d	weight ~kg
		max/min mm	mm	min mm	min mm	mm	Thread NPT	
3/4	25	25.031	24.980	14	13	28	1/2	0.031
1	30	30.055	29.975	14	13	33	1/2	0.058
1 1/4	38	38.070	37.990	14	13	41	1/2	0.112
1 1/2	44.5	44.570	44.490	14	13	47.5	1/2	0.165
2	57	57.200	57.120	17	16	60	1/2	0.350
1	30	30.055	29.975	14	13	33	3/4	0.037
1 1/4	38	38.070	37.990	14	13	41	3/4	0.091
1 1/2	44.5	44.570	44.490	14	13	47.5	3/4	0.143
2	57	57.200	57.120	17	16	60	3/4	0.324
1 1/4	38	38.070	37.990	14	13	41	1	0.061
1 1/2	44.5	44.570	44.490	14	13	47.5	1	0.114
2	57	57.200	57.120	17	16	60	1	0.288
1 1/2	44.5	44.570	44.490	14	13	47.5	1 1/4	0.057
2	57	57.200	57.120	17	16	60	1 1/4	0.219
2	57	57.200	57.120	17	16	60	1 1/2	0.161

Threaded Outlets

Self Reinforced Branch Connector

Threaded Type

Threaded Outlets
16 mm – 965mm x
1/2" – 2" NPT

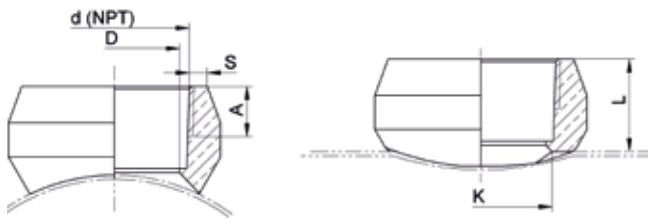

section view

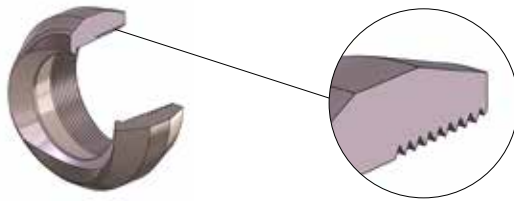

Threaded Outlets

Dimensions Table 16/1/2" - 965/38" x 16/1/2" - 57/2" - 16/20 bar

Nominal Branch Size	Header Size Ranges	L Nom	D Nom	K Nom	A min	S
in	mm	mm	mm	mm	mm	mm
1/2	16 - 965	24	13.84	14.0 - 21.0	13.5	4.78
3/4	25 - 965	24	18.88	21.0 - 26.0	14.0	5.56
1	30 - 965	28	24.30	26.8 - 33.0	17.5	6.35
1 1/4	38 - 965	30	32.50	34.8 - 42.0	18.0	6.35
1 1/2	44.5 - 965	33 - 34	38.14	53.8 - 59.5	18.5	7.14
2	57 - 965	34 - 38	49.22	53.8 - 59.5	19.0	8.74

Socket Outlets

Self Reinforced Branch Connector

Socket Welding Type

Socket Outlets
16 mm - 57 mm x
16 mm - 965 mm

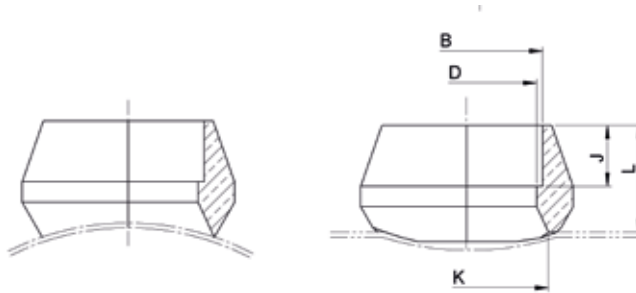

section view

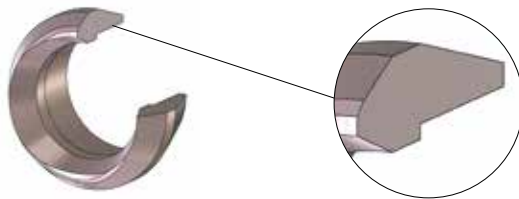

Socket Outlets

Dimensions Table 16/1/2" - 965/38" x 16/1/2" - 57/2" - 16/20 bar

Branch Specified OD mm	Header Size Ranges mm	L		D		K		J		B		S	
		Nom mm	max/min mm	Nom mm	max/min mm	Nom mm	max/min mm	Nom mm	max/min mm	min/max mm	min/max mm	min/max mm	min/max mm
16	16 - 965	18	11.565 - 12.445	12.8	- 17	10	16.070 - 16.121	1.8	- 2				
25	25 - 965	23	20.575 - 21.445	26	- 26	13	25.080 - 25.131	1.8	- 2				
30	30 - 965	26	24.475 - 25.555	31	- 31	13	30.080 - 30.131	2.25	- 2.5				
38	38 - 965	29	32.490 - 33.570	34.8	- 40	13	32.490 - 33.570	2.25	- 2.5				
44.5	44.5 - 965	32	38.990 - 40.070	41.3	- 45	13	38.990 - 40.070	2.25	- 2.5				
57	57 - 965	36	51.620 - 52.700	53.8	- 58	16	57.225 - 57.276	2.25	- 2.5				

Capillary Brazing End Caps Socket Welding End Caps / NPT End Caps

Capillary Brazing, Socket Weld
Fittings and Miscellaneous

End Caps
16 mm - 57 mm

CB

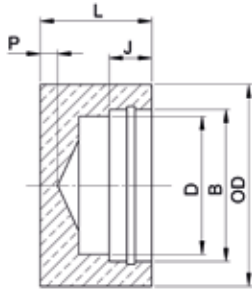

SW

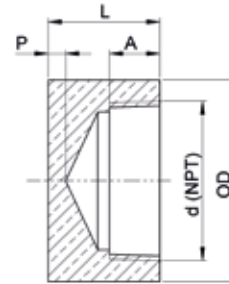
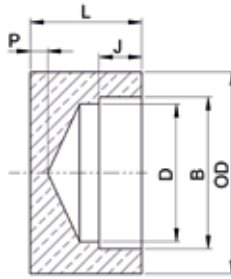

NPT End Caps
16 mm - 57 mm

section view

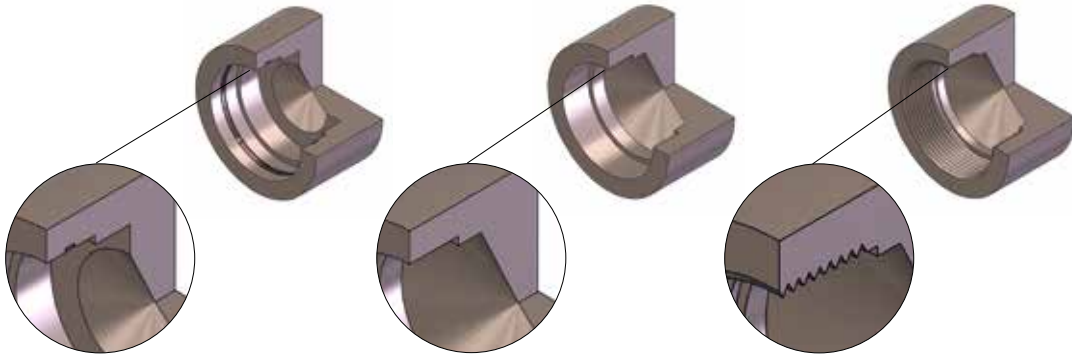

Dimensions Table

nominal		specified		OD		B		D	L	P	J	A	d	weight
in	mm	min	max/min	min	min	min	min	min	min	min	min	min	NPT	~kg
		mm	mm	mm	mm	mm	mm	mm	mm	mm	mm	mm		
1/2	16	29	16.121 16.070	12	32	6.5	10	13.5	1/2	0.149				
3/4	25	35	25.131 25.080	21	37	6.5	13	14.0	3/4	0.216				
1	30	44	30.131 30.080	25	38	6.5	13	17.5	1	0.363				
1 1/4	38	57	38.146 38.095	33	41	6.5	13	18.0	1 1/4	0.665				
1 1/2	44.5	64	44.646 44.595	39.5	41	6.5	13	18.5	1 1/2	0.814				
2	57	76	57.276 57.225	52	42	6.5	16	19.0	2	1.098				

Male Nipple one / Male Nipple both

Male Nipple one
1/2" - 2" x
21,3mm - 60,3mm

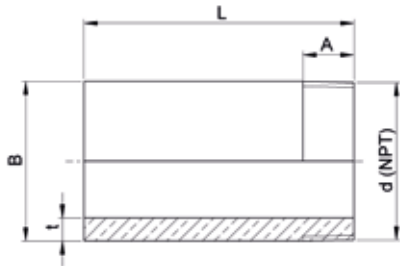

Male Nipple both
21,3mm - 60,3mm

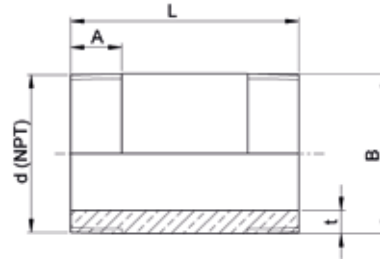

section view

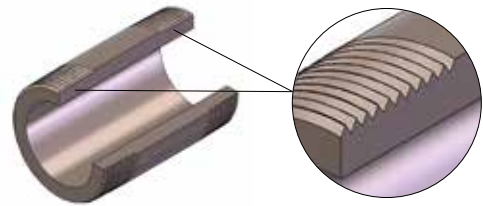
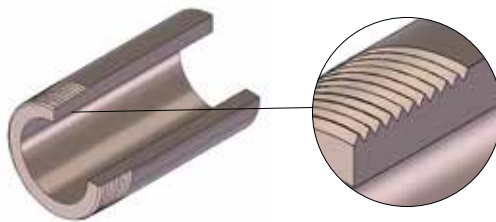

Dimensions Table Male Nipple one

nominal	B specified	d	L	A	t	weight
in	mm	Thread NPT	min mm	min mm	mm	~kg
1/2	21.3	1/2	76.2	13.6	4.78	0.167
3/4	26.7	3/4	76.2	13.9	5.56	0.248
1	33.4	1	76.2	17.3	6.35	0.362
1 1/4	42.2	1 1/4	76.2	18.0	6.35	0.479
1 1/2	48.3	1 1/2	76.2	18.4	7.14	0.619
2	60.3	2	76.2	19.2	8.74	0.950
1/2	21.3	1/2	101.6	13.6	4.78	0.223
3/4	26.7	3/4	101.6	13.9	5.56	0.332
1	33.4	1	101.6	17.3	6.35	0.484
1 1/4	42.2	1 1/4	101.6	18.0	6.35	0.641
1 1/2	48.3	1 1/2	101.6	18.4	7.14	0.828
2	60.3	2	101.6	19.2	8.74	1.270

Female Adapter / Male Adapter

Female End Adapter
16 mm - 57 mm

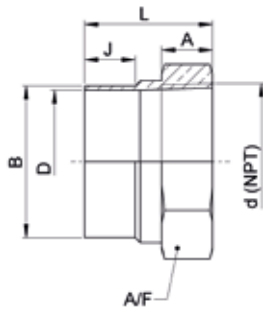

Male End Adapter
16 mm - 57 mm

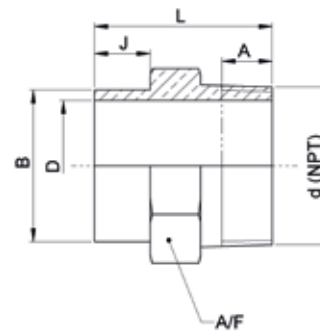

section view

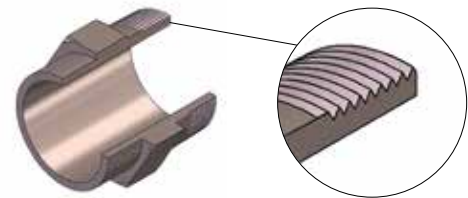
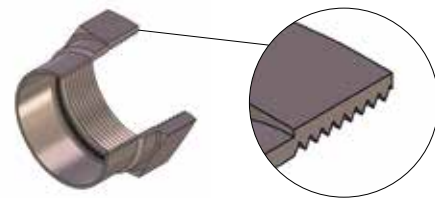

Dimensions Table Female Adaptor

nominal	specified	d		B	D	L	J	A	A/F	weight
		Thread	max/min							
in	mm	NPT	mm	mm	mm	mm	mm	mm	mm	~kg
1/2	16	1/2	16.045 15.965	12	36	13	13.5	27	0.070	
3/4	25	3/4	25.055 24.975	21	39	16	14	32	0.110	
1	30	1	30.055 29.975	25	43	16	17.5	41	0.190	
1 1/4	38	1 1/4	38.070 37.990	33	44	16	18	50	0.240	
1 1/2	44.5	1 1/2	44.570 44.490	39.5	44	16	18.5	55	0.290	
2	57	2	57.200 57.120	52	48	19	19	70	0.470	

Dimensions Table Male Adaptor

nominal	specified	d		B	D	L	J	A	A/F	weight
		Thread	max/min							
in	mm	NPT	mm	mm	mm	mm	mm	mm	mm	~kg
1/2	16	1/2	16.045 15.965	12.0	44	15	13.5	27	0.100	
3/4	25	3/4	25.055 24.975	18.9	50	18	14	32	0.140	
1	30	1	30.055 29.975	24.3	56	18	17.5	41	0.240	
1 1/4	38	1 1/4	38.070 37.990	32.5	58	18	18	50	0.340	
1 1/2	44.5	1 1/2	44.570 44.490	38.1	61	18	18.5	55	0.440	
2	57	2	57.200 57.120	49.2	67	21	19	70	0.740	

Hexagon Plug / Round Plug

Hex. Plug
21,3 mm – 60,3 mm
1/2" – 2"

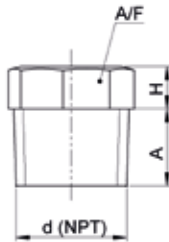

Round Plug
1/2" – 2"

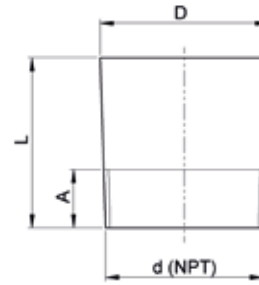

section view

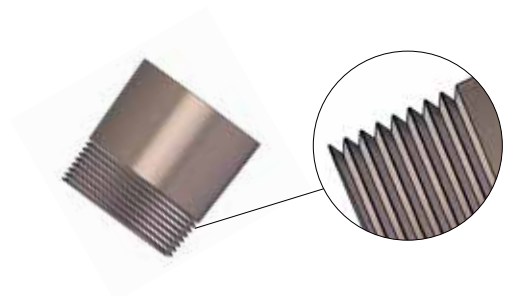
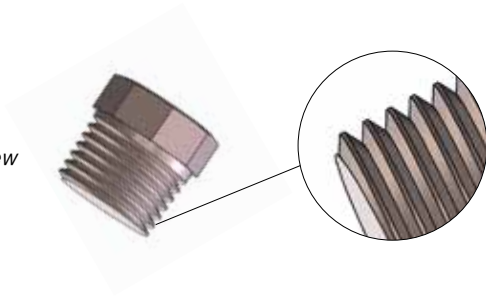

Dimensions Table

nominal size=	Length	Width of flats	Hex height	Lenght	Dia of Head	Hex.	Round
Thread d	A	A/F	H	L	D	Head weight	Head weight
NPT	min	min	min	min	min	~kg	~kg
in	mm	mm	mm	mm	mm		
1/2	14.5	22	8	44	21	0.074	0.135
3/4	16.0	27	10	44	27	0.133	0.219
1	19.0	36	10	51	33	0.242	0.386
1 1/4	20.5	44.5	14	51	43	0.461	0.641
1 1/2	20.5	51	16	51	48	0.645	0.616
2	22.0	63.5	17	64	60	1.073	1.603

Appendix A

Pressure/temperature ratings of flanges

Type of Flange	Size Range	Maximum Allowable Working Pressure-bar							
		16 bar system				20 bar system			
		38°C	50°C	75°C	100°C	38°C	50°C	75°C	100°C
Composite weld neck (section 1)	½ in/16 mm to 4 in/108 mm	see 20 bar system				20	19.7	18.6	17.3
	6 in/159 mm to 36 in/914 mm	16.0	16.0	16.0	15.7	20	19.7	18.6	17.3
Composite slip-on (section 2)	½ in/16 mm to 4 in/108 mm	see 20 bar system				20	19.7	18.6	17.3
Solid weld neck (section 3)	½ in/16 mm to 4 in/108 mm	see 20 bar system				20	19.7	18.6	17.3
	6 in/159 mm to 36 in/914 mm	16.0	16.0	16.0	15.7	20	19.7	18.6	17.3
Solid slip-on (section 4)	½ in/16 mm to 4 in/108 mm	see 20 bar system				20	19.7	18.6	17.3

Surface finish of the copper-nickel stub end and flangejoint faces

Method of machining	Ra* µm		Rz* µm	
	min.	max.	min.	max.
turning	3.2	12.5	12.5	50

Note

The term "turning" includes any method of machining producing concentric or spiral grooves.

Pressure/temperature ratings - fittings

Type of Fitting	Size Range	Maximum Allowable Working Pressure-bar							
		16 bar rating				20 bar rating			
		38°C	50°C	75°C	100°C	38°C	50°C	75°C	100°C
Butt welding fittings	1 in/30 mm to 4 in/108 mm	use 20 bar				20	19.7	18.6	17.3
	6 in/159 mm to 36 in/914 mm	16.0	16.0	16.0	15.7	20	19.7	18.6	17.3
Socket weld fittings	½ in/16 mm to 2 in/57 mm	use 20 bar				20	19.7	18.6	17.3
Capillary brazed fittings	½ in/16 mm to 2 in/57 mm					20	19.7	18.6	17.3

Mechanical Properties

	Tensile Strength				0.2 % Proof Stress		Elongation	Hardness
	N/mm ²		PSI		N/mm ²	PSI	% min	HV5
	min.	max.	min.	max.			on L = 5.65 √S ₀	max
Seamless Pipes	300	380	43.512	55.115	105	15.229	30	
Seam-welded pipes	280	-	40.611	-	105	15.229	30	120*
Weld neck and slip-on stub ends, solid weld neck and slip-on flanges	280	-			105	15.229	30	120*
Fittings	280	-	40.611		105	15.229	30	120*

* Determined on finished tube outside of heat affected zone

Appendix B

Temperature Range	SI Units	US Costomary Units	20°C	68°C	100°C	212°C	200°C	392°C	300°C	572°C	400°C	752°F
Thermal Expansion Coefficient	10-16/°K	10-16/°K			16.4	9.1	16.8	9.3	17.1	9.5	17.5	9.7
Young´s Modulus	kN/mm ²	ksi	124	18.000	118	17.110	112	16.240	106	15.370	100	14.500
Modulus of Rigidity	kN/mm ²	ksi	50	6.800								
Poisson´s Ratio	-	-	0.35		0.36		0.36		0.36			
Density	g/cm ³	pound/inch ³	8.91	0.321								
Thermal Conductivity	W/m°K	Btu/pound °F	51.7	29.9	60.2	34.8	70	40,5	78.9	45.6	86.7	50.1
Specific Heat Capacity	kJ/kg°K	BTU/pound °F	0.377	0.09								
Electrical Conductivity	MegaSiemens/cm	%IACS	0.053	9								
Electrical Resistivity	microhm-cm	circular mil ohm/foot	19.12	115.0								

Appendix C

Adjust the description of dimensions to the images

Size	90 deg & 45 deg elbows & tees (see tables 1.4, 1.6 & 1.7)	reducer (see table 1.9)	end caps (see table 1.8)
Specified OD	centre-to-end dimension D, E, C & M	overall lenght H	overall lenght h1 + h2
up to and including 267	± 2	± 2	+0.015 D ₀ -0
323.9 up to and including 711	± 3	± 3	
813 up to and including 914	± 5	± 5	

Design Scope

Working pressures and temperatures of components included in this specification:

1. 16 bar/232 psi: -29°C/-20°F to +75°C/+167°F
2. 20 bar/290 psi: -29°C/-20°F to +38°C/+100°F

Pipes Seamless and Welded:

- Pipes are based on BS MA 60, DIN 86007, and ANSI/ASME B31.3
- The wall thicknesses comply with ANSI B31.3 and DIN 86007 as well as International Association of Classification Societies with additional allowances for robustness to withstand mechanical damage, especially in the smaller sizes.
- The fit-for-purpose corrosion allowance of 0.5 mm sufficient for entire service life of the piping installation has been included. This corrosion allowance is in accordance with all major classification societies specified for alloys containing ≥10 wt. % Ni and ≥1.5 wt. % Fe. Mechanical properties of pipes are given in Appendix A.

Flanges Composite and Solid:

- Included series of composite (lap type) and solid flanges in metric dimensions based on ANSI B16.5, MSS SP-44 and BS 1560
- The basic metric dimensions for drilling and flange outside diameters are those given in ANSI B16.5 and MSS SP 44 Class 150 rating with inch size bolting.
- The copper-nickel stub end and flange joint faces are machine finished and comply with the corresponding Sections of EEMUA 145 and are summarized in the Appendix A.
- Mechanical properties pressure/temperature ratings of flanges are given in Appendix A.

Fittings:

- The specification comprises a series for pipe fittings including butt weld, socket welding, capillary brazing, threaded, self-reinforced fittings as well as saddle pieces.
- The “building in” dimensions of the butt welding fittings are based on ANSI B16.9 apart from the caps that are based on DIN 28011 (with suitable amendments).
- Mechanical properties pressure/temperature ratings of fittings are given in Appendix A.

Physical Properties of CuNi 90/10

The physical properties of the alloy are given by Appendix B. The basic allowable stresses in tension are in accordance with ASME B31.3 Table A-1.

Welding

The welding consumables used for the manufacturing of welded components are in accordance with AWS-A5.7 Class ER CuNi. The welding procedure specification and welder qualification are in accordance with ASME code, section IX.

Testing of Welds

The weld seams are examined by the liquid dye penetrant testing in accordance with ASME code, section VIII, division 1, appendix 8. The radiographic examination is performed for the complete length of each weld to meet the requirements of ASME code, section VIII, UW51.

Gaskets

The gaskets normally used with flanges are those made from aramid fibre with nitrile binder in accordance with ASME B16.21 or equivalent. The gasket hardness shall not be less than 75 Shore. The gaskets shall not be graphited. In order to ensure adequate seating when solid weldneck and solid slip-on flanges are used, irrespective of gasket materials, the gaskets shall be located within the bolt circle. Note: Gaskets should not be used when mating with elastomer/rubber faced flanges.

Suggested Branch Connections

Suggested branch connections are provided by Appendix D.

PDMS Data

The components mentioned in this catalogue are available in the PDMS-format. Please contact us for more information.





KME Quality-Management



KME is committed to the continuous improvement of all our business and production processes in terms of efficiency, effectiveness and reliability as regards their organisation, technological aspects and staff management.

The aim of our commitment is to increase the satisfaction of all stakeholders.

We are constantly engaged in:

- creating products of outstanding quality
- preventing errors and defects
- minimising the costs associated with errors and inefficiencies
- preventing the waste of resources
- establishing safe production conditions to protect both our employees and the environment

We aim for excellence by means of transparent management systems designed to satisfy the requirements of our clients together with the demands of the market and technology.

The quality management systems implemented throughout the KME Group are fully compliant with the provisions of ISO 9001 as well as, in the case of our automotive industry clients, ISO TS 16 949, and our staff is strongly committed to their implementation at all levels.



KME Germany GmbH & Co. KG

Marine Applications

P.O. Box 3320

49023 OSNABRÜCK

Klosterstraße 29

49074 OSNABRÜCK

GERMANY

Fon +49 541 321-3220

info-maritime@kme.com

www.marine-applications.com

www.kme.com

Marine Applications



® = registered trademark

All changes reserved.

Owing to limitations in printing technology, the colours reproduced in this brochure should be regarded as approximate equivalents to the colours described.

0814.010.0108